

**BEDU**  
≡ POMPEN ≡

# Waste water and process pumps

PC / PC-VM



**made for your process**



# PC / PC-VM

## Waste water and process pumps



### Handles liquids

Domestic and industrial waste water, raw sewage, viscous and corrosive liquids, liquids with fibrous and solid substances.

### Technical Data

**Discharge Flange** — DN 40 up to DN 300 mm

**Capacity** — up to 1600 m<sup>3</sup>/h

**Head** — up to 95 m

**Speed** — up to 2900 rpm

**Operating Temperature** — -10 °C up to 110 °C

**Casing Pressure (Pmax)** — 10 bar (16) bar \*

(Pmax : Suction Pressure + Shut off Head)

(\*) The material of pumps differ according to the type of pumped liquid, operating temperature and pressure. Contact our company for detailed information.

### Desing Features

Horizontal / Vertical, radially split wide volute casing, single stage, end suction centrifugal pumps with closed, semi-open or vortex type impeller.

18 basic sizes covering wide range of operational area.

Due to the back-pull-out design the complete bearing assembly including impeller and shaft seal can be dismantled without removing the volute casing from the pipe system. (With spacer coupling application, also possible to take out the rotor group without dismantling the electric motor.)

Discharge flanges conform to EN 1092 - 2 / PN10 (PN16\*).

All impellers are dynamically balanced according to ISO 1940 Class 6.3.

Axial thrust is balanced by impeller back ribs.

Direction of rotation is clockwise viewed from driver end.

Bearings of PCVM type pumps are "life time grease lubricated" ball bearings up to 150-315 size. For bigger sizes oil lubricated bearings are used. In vertical design PC-VM) always grease lubricated bearings are used.

### Shaft Sealing

Depending on request or requirement, pumps with soft packing or single, double and cartridge type mechanical seals can be supplied.

### Pump Designation

**PC -VM 250 - 315 AB**

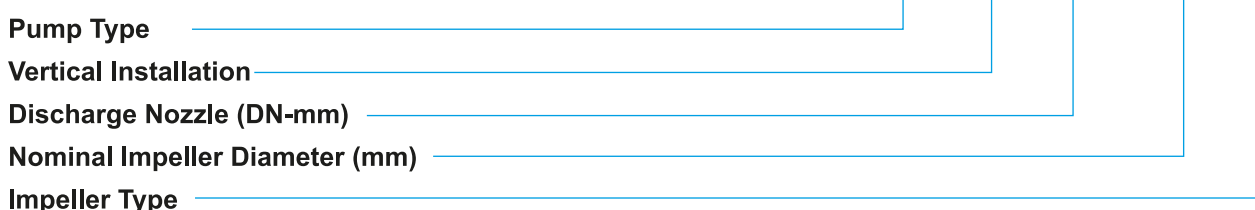

# Impeller Type

# PC / PC-VM

**B Type Impeller:** Closed type impellers with wide channels capable of pumping large size solid particles without clogging, for big capacity and low pressure. It is more suitable for 4 pole motors (1450 or 1750 RPM)

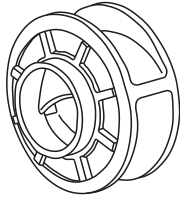

**D Type Impeller:** It is also closed type, suitable for high speed motors (2900 or 3500 RPM). It is convenient for high pressure, small capacity and smaller size solid particles.

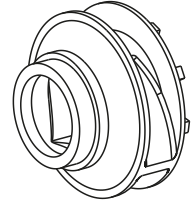

**VX Type Impeller:** Free vortex type semi-open impeller is placed on top of the volute. It can pump the solid particles without touching them. It is also suitable for fibrous materials.

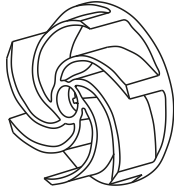

**AB Type Semi-Open Impeller:** Closed type impellers with wide channels capable of pumping large size solid particles without clogging, for big capacity and low pressure. It is more suitable for 4 pole motors (1450 or 1750 RPM). Designed for aggressive applications impeller works against a wear plate.

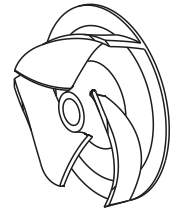

## Field Chart

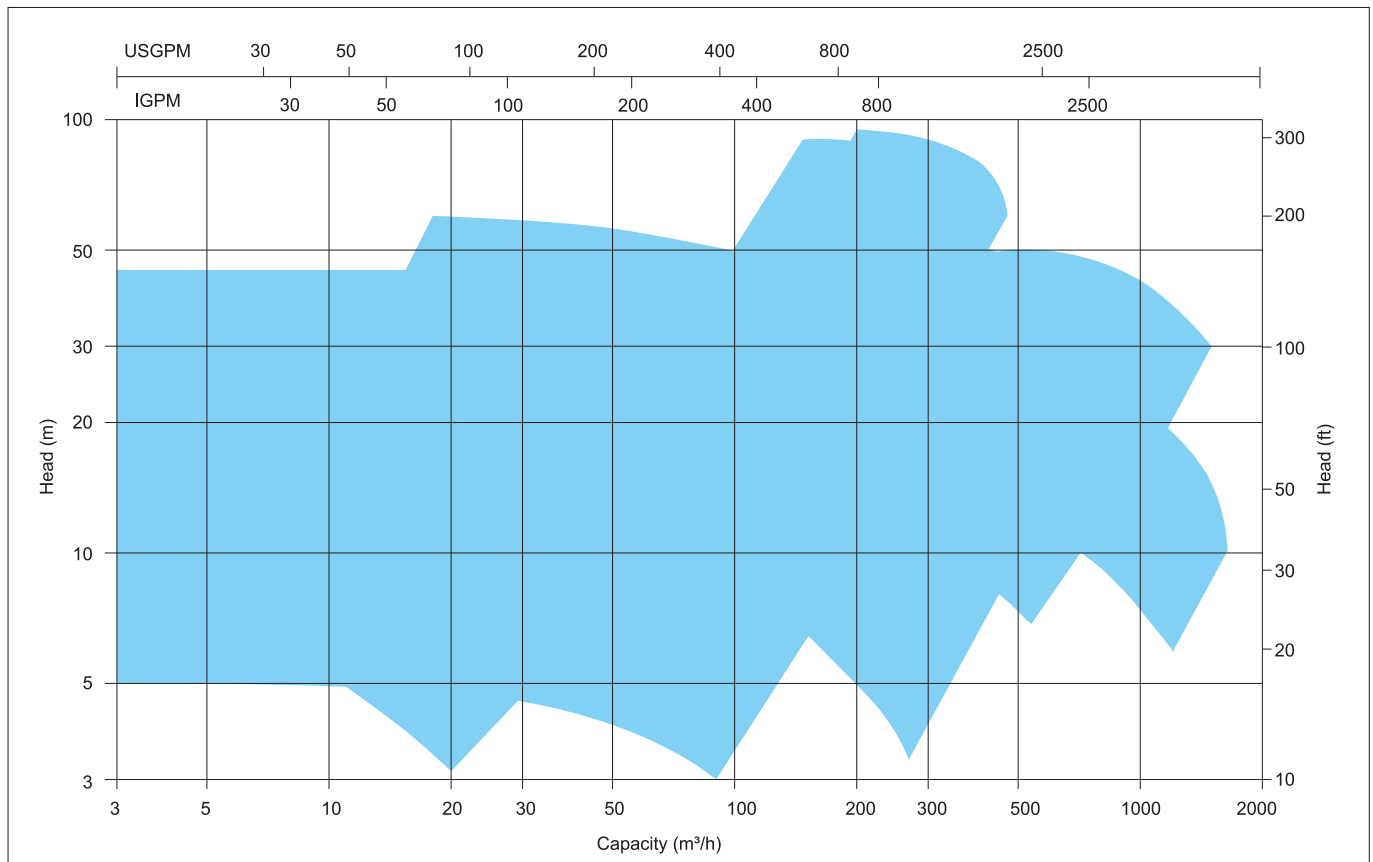

## Horizontal Installation (PC)

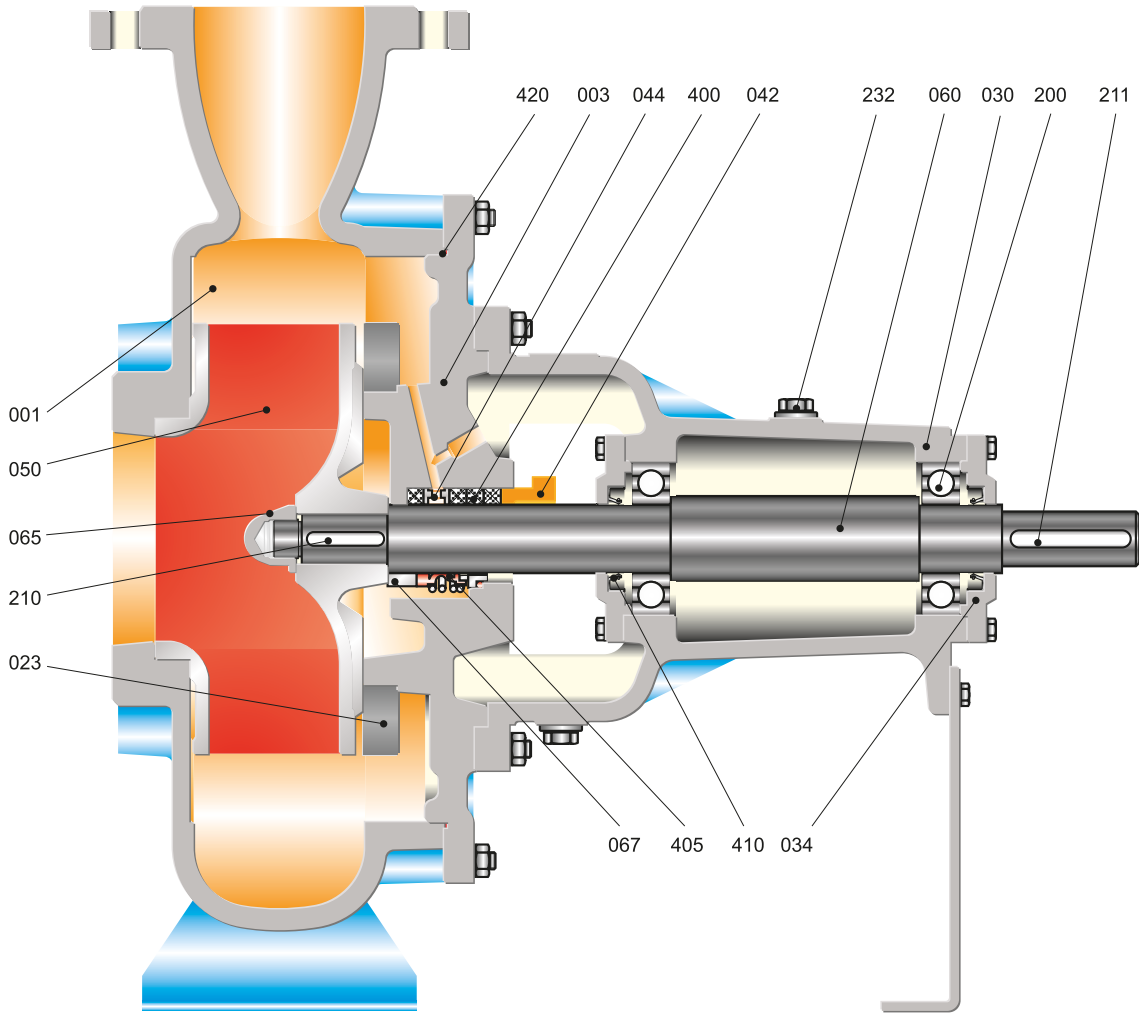

## Semi-open Impeller Application

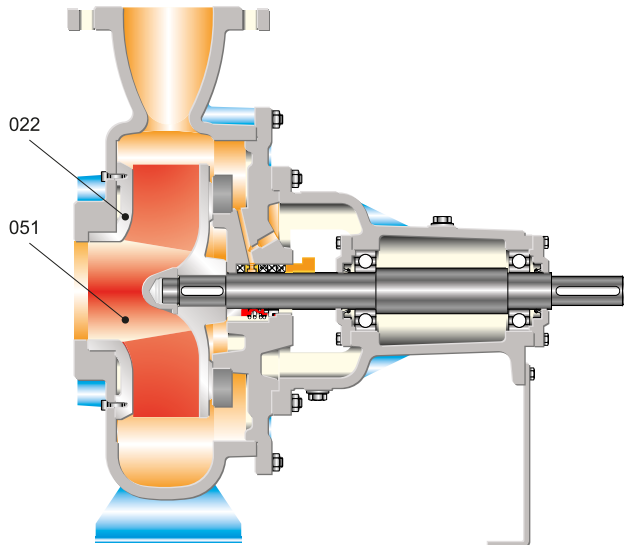

## Heavy Duty Type Bearing Application

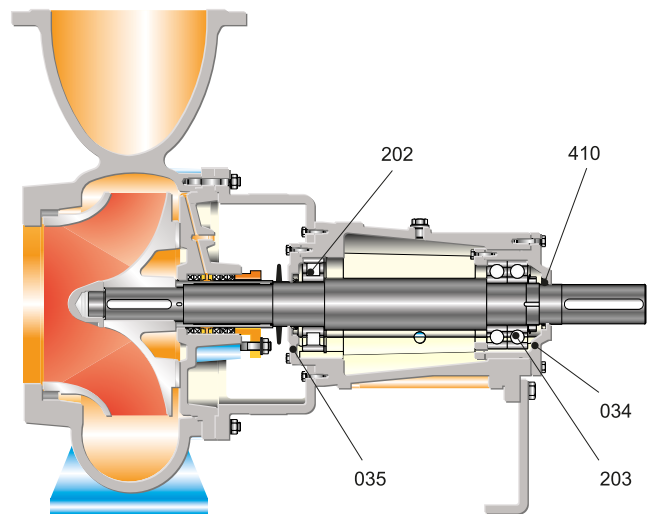

## Vertical Installation (PC-VM)

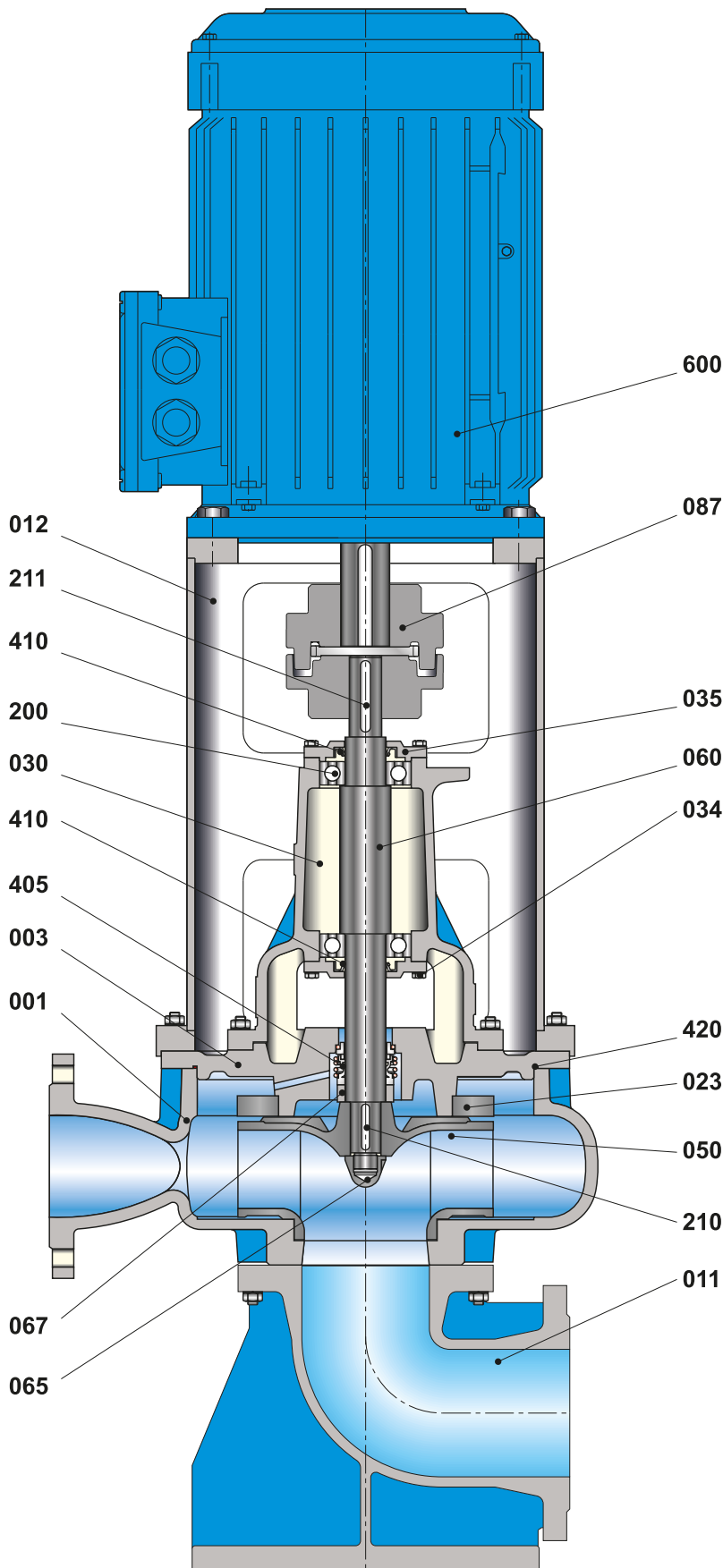

## Part List

- 001 Volute Casing
- 003 Casing Cover
- 011 Frame Foot
- 012 Motor Pedestal
- 022 Wear Plate
- 023 Back Wear Plate
- 030 Bearing Housing
- 034 Bearing Cover
- 035 Bearing Cover
- 042 Gland
- 044 Lantern Ring
- 050 Impeller
- 051 Semi-open Impeller
- 060 Pump Shaft
- 065 Impeller Nut
- 067 Spacer Sleeve
- 087 Flexible Coupling
- 200 Ball Bearing
- 202 Roller Bearing
- 203 Angular Contact Ball Bearing
- 210 Impeller Key
- 211 Coupling Key
- 232 Oil Filling Plug
- 400 Soft Packing
- 405 Mechanical Seal
- 410 Lip Seal
- 420 O-Ring
- 600 Electric Motor

# Technical Data

# PC / PC-VM

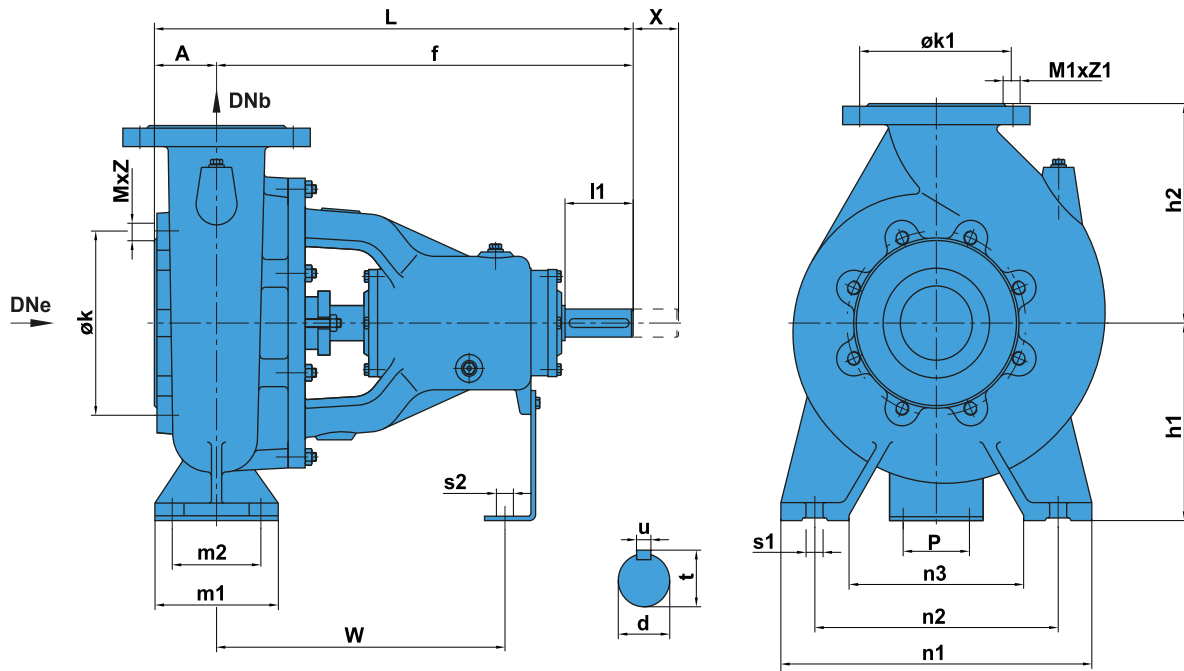

Pump Type	DNc	DNb	PUMP DIMENSIONS (mm)																		FLANGE DIMENSIONS				
			A	f	L	h1	h2	m1	m2	n1	n2	n3	s1	P	s2	W	d	l1	t	u	x**	k	MxZ	k1	M1xZ1
40-160	50	40	82	348	430	160	180	100	70	240	190	140	14	110	14	247	24	50	27	8	140	125	M16x4	110	18x4
50-160	65	50	100	350	450	160	180	100	70	270	212	160	14	110	14	270	24	50	27	8	140	145	M16x4	125	18x4
50-200	65	50	105	360	465	160	200	100	95	270	210	160	14	110	14	270	24	50	27	8	140	145	M16x4	125	18x4
65-200	80	65	108	372	480	180	225	125	95	330	255	190	14	110	14	260	24	50	27	8	140	160	M16x8	145	18x4
80-160	100	80	83	384	467	180	180	120	85	310	250	190	14	110	14	288	24	50	27	8	140	180	M16x8	160	18x8
80-200	100	80	83	488	571	180	220	125	90	350	280	215	18	110	14	358	32	80	35	10	140	180	M16x8	160	18x8
80-315	100	80	55	480	535	250	310	125	95	400	315	240	18	110	14	350	32	80	35	10	140	180	M16x8	160	18x8
100-240	125	100	82	492	574	225	250	160	110	370	280	205	20	110	14	357	32	80	35	10	140	210	M16x8	180	18x8
100-270	125	100	97	500	597	275	310	160	110	430	345	270	20	110	14	371	32	80	35	10	140	210	M16x8	180	18x8
100-315	125	100	97	500	597	275	310	160	110	430	345	270	20	110	14	371	32	80	35	10	140	210	M16x8	180	18x8
150-315	150	150	119	638	757	280	355	200	150	500	400	300	23	110	14	445	42	110	45	12	200	240	M20x8	240	23x8
150-500	150	150	126	782	908	425	600	250	200	720	600	435	28	140	20	562	55	110	59	16	200	240	M16x8	240	23x8
200-315	200	200	165	707	872	355	450	250	200	600	500	360	24	110	14	543	48	110	51	12	250	295	M20x8	295	23x8
200-400	200	200	142	757	899	380	530	250	200	600	500	360	24	140	20	536	55	110	59	16	250	295	M20x8	295	23x8
200-500	180	200	126	968	1094	425	600	300	240	270	580	435	28	140	20	700	70	140	74,5	20	170	240	M16x8	295	23x12
250-315	250	250	145	1003	1148	335	475	300	230	680	540	400	27	140	20	730	70	140	74,5	20	265	295	M20x8	350	23x12
300-400	300	300	201	974	1175	400	560	300	240	720	600	435	27	140	20	700	75	140	79,5	20	285	400	M20x12	400	23x12
300-500	300	300	201	974	1175	450	600	300	230	800	660	520	27	140	20	730	75	140	79,5	20	300	410	M20x12	400	23x12

Dimensions may differ according to bearing housing type (normal, heavy duty etc). We have rights to make change with the dimensions.

( \*\* ) Gap necessary for the withdrawal of the pump rotor from the driven end without the need for disconnecting the motor and pipework (spacer coupling application).

## Material Options

Part List	0.6025	0.7040	1.0619	1.4308	1.4309	1.4408	1.4409	1.4500	1.4517	1.4469	1.4317	2.1050.01	2.0975.01	1.0503	1.4021	1.4301	1.4306	1.4401	1.4404	1.4462
Volute Casing	●	○	○	○	○	○	○	○	○	○	○	○	○							
Casing Cover	●	○	○	○	○	○	○	○	○	○	○	○	○							
Impeller	●	○	○	○	○	○	○	○	○	○	○	○	○							
Shaft														●	○	○	○	○	○	○
Bearing Housing	●	○																		
Front Wear Plate	○	○	○	○	○	○	○	○	○	○	○	○	○							
Back Wear Plate	●	○	○	○	○	○	○	○	○	○	○	○	○							
Spacer Sleeve														○	○	○	○	○	○	○

Mechanical Seal (\*)

EN 12756 / DIN 24960

(\*) Optional : Depending on customer requirement or request different types and brands of mechanical seals are applicable.

● manufacturing  
○ Optional

## Material Equivalents

Descriptions	DIN 17007	EN-DIN	ASTM
Cast iron	0.6025	GJL-250 (GG 25)	A 48 Class 40-B
Nodular cast iron	0.7040	GJS-400-15 (GGG 40)	A 536 Gr. 60-40-18
Cast steel	1.0619	GP240GH (GS-C 25)	A 216 Gr. WCB
Chrome nickel cast steel	1.4308	G-X5 Cr Ni 19-10	A 351/743/744 Gr. CF8
Chrome nickel cast steel (low carbon)	1.4309	G-X2 Cr Ni 19-11	A 351/743/744 Gr. CF3
Chrome nickel molybdenum cast steel	1.4408	G-X5 Cr Ni Mo 19-11-2	A 351/743/744 Gr. CF8M
Chrome nickel molybdenum cast steel (low carbon)	1.4409	G-X2 Cr Ni Mo 19-11-2	A 351/743/744 CF3M
Austenitic cast steel	1.4500	G-X7 Cr Ni Mo Cu Nb 25-20	A 351/743/744 (CN7M)
Austenitic-ferritic cast steel (duplex)	1.4517	G-X2 Cr Ni Mo Cu N 25-6-3-3	A 890 Gr. 1B (CD4MCuN)
Austenitic-ferritic cast steel (super duplex)	1.4469	G-X2 Cr Ni Mo N 26-7-4	A 890 Gr. 5A (CE3MN)
Martenzitic Stainless Cast Steel	1.4317	GX4 Cr Ni 13-4	A 351/743/744 (CA6NM)
Cast bronze (tin alloy)	2.1050.01	G-Cu Sn 10	B 584 C 90700
Cast bronze (nickel alloy)	2.0975.01	G-Cu Al 10 Ni	B 148 C 95800
Carbon steel	1.0503	C 45	A 29/108/576 1045
Chrome steel	1.4021	X20 Cr 13	A 276 Type 420
Chrome nickel steel	1.4301	X5 Cr Ni 18-10	A 276 Type 304
Chrome nickel steel (low carbon)	1.4306	X2 Cr Ni 19-11	A 276 Type 304L
Chrome nickel molybdenum steel	1.4401	X5 Cr Ni Mo 17-12-2	A 276 Type 316
Chrome nickel molybdenum steel (low carbon)	1.4404	X2 Cr Ni Mo 17-12-2	A 276 Type 316 L
Duplex (austenitic-ferritic) steel	1.4462	X2 Cr Ni Mo N 22-5-3	A 276 S 31803

## Flange Dimensions

DN <sub>e</sub> /DN <sub>b</sub>	D <sub>f</sub>	k	s	n
40	150	110	19	4
50	165	125	19	4
65	185	145	19	4
80	200	160	19	8
100	220	180	19	8
125	250	210	19	8
150	285	240	23	8
200	340	295	23	12
250	405	355	28	12
300	460	410	28	12

" n " number of holes

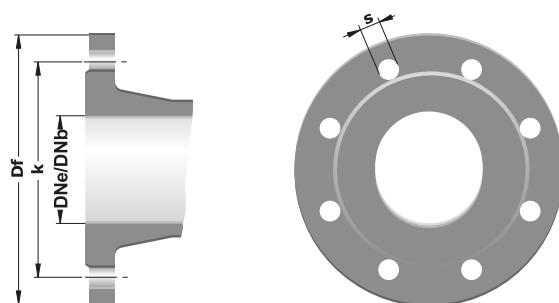





The logo consists of the word "BEDU" in a large, bold, white sans-serif font, with "POMPEN" in a smaller, white sans-serif font below it. The text is centered within a dark teal square, which is itself centered within a white square border. The background of the entire page is a faded industrial scene with various pipes, tanks, and structures.

**BEDU**  
POMPEN

## made for your process

- Expert advice
- A customer-oriented organization that adapts to the requirements and wishes of your organization
- Innovative and customized solutions
- Breakdownservice, 24 hours a day, 7 days a week
- Technical service with extensive test facilities, working from our own workplace or at your location
- A fast and appropriate solution for all your issues
- Wide range of liquid pumps
- Repair, maintenance and revision

BEDU POMPEN B.V.  
Poort van Midden Gelderland Rood 10  
6666 LT HETEREN  
Nederland  
Telefoon +31 (0)88 4802 900  
E-mail [sales@bedu.eu](mailto:sales@bedu.eu)

[WWW.BEDU.NL](http://WWW.BEDU.NL)

BEDU BELGIUM B.V.B.A.  
Industriepark-West 75  
9100 SINT-NIKLAAS  
België  
Telefoon +32 (0)3 80 87 980  
E-mail [sales@bedu.eu](mailto:sales@bedu.eu)

[WWW.BEDU.BE](http://WWW.BEDU.BE)

