

BEDU
≡ P O M P E N ≡

**Instruction for installation,
operation & maintenance**

Contractor pumps

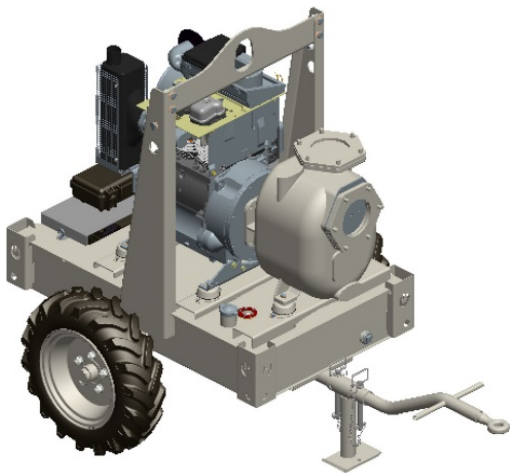

S

made for your process



EC - Declaration of Conformity

Manufacturer Details

Tradename

Bedu Pompen BV

Address

Poort van Midden Gelderland Rood 10, 6666 LT, Heteren, Netherlands

Product Details

Product Name

Centrifugal pumps

Model (+series) Name

Contractor pumps S

Applicable Standards Details

Directives

2006/42/EC (Machinery Directive)
2014/35/EU (Low Voltage Directive)
2014/30/EU (Electromagnetic compatibility)

Standards

EN-ISO 12100:2010
EN-IEC 60204-1:2006
EN 809+A1/C1

Additional information

No further details.

Declaration

We hereby declare under our sole responsibility that the product(s) mentioned above to which this declaration relates complies with the above mentioned standards and Directives.

Business Unit Manager: Issued Date:

01/10 2014

BEDU Pompen BV

Poort van Midden Gelderland Rood 10
6666 LT Heteren

Tel : +31 (0)88 - 4802 900

Fax : +31 (0)88 - 4802 901

E-mail : info@bedu.nl

Website : www.bedu.eu

Marco Breunissen

Signature of representative(s)

B. Introduction

1. Introduction

- 1.1 The instruction manual contains important information on how to operate the pump safely, properly and most efficiently. Observing these instructions help to avoid danger, to reduce repair costs, downtimes and to increase the reliability and life of pump.
- 1.2 The operating instructions must always be available wherever the pump is in use.
- 1.3 The operating instructions must be read and applied by any person in charge of carrying out work on the pump.
- 1.4 Observe the mandatory rules and regulations for accident prevention and environmental protection in the country and place of use of the pump. The generally recognized technical rules for safe and proper working must also be observed.
- 1.5 It is presumed that fundamental project work as well as all work with regard to transport, assembly, installation, start-up, maintenance and repair is performed by qualified personnel or supervised by skilled labor taking overall responsibility.

2. Safety

- 2.1 A pump that is installed incorrectly, operated wrongly, or maintained poorly can present a hazard. If the following considerations are overlooked, the safety of personnel or satisfactory operation of the pump may be endangered.
- 2.2 Attention must be given to the safe handling of all items. Where pumps, pump units or components weigh in excess of 20 kg (44 lb.), it is recommended that suitable lifting equipment should be used in the correct manner to ensure that personal injury or damage to pump components does not occur.

<p>WARNING Note that lifting loops fitted to individual pieces such as on the pump or motor are designed to lift only this part and not the complete assembly.</p>

- 2.3 Before starting to dismantle a pump all relevant and appropriate safety precautions must be taken, particularly if the pumps have been handling hazardous or toxic products. Seek advice from your safety officer or the manufacturer if you have any doubts.
- 2.4 Always wear adequate protective clothing and eye protection when dismantling pumps that have been used to pump toxic or hazardous products. Breathing apparatus may be necessary.
- 2.5 Always isolate the pump electrically before dismantling. Ensure that the electrical switch gear cannot be operated whilst any work is being carried out on the pump.
- 2.6 Always drain the pump casing of fluids before removing the pump from its associated pipe-work.
- 2.7 Flush out the pump casing with a compatible liquid and drain it in a safe area.
- 2.8 Check with your responsible officer to see if any special decontamination procedures have to be followed before working on a pump.
- 2.9 All pumps returned for factory servicing must be decontaminated and labeled to inform what precautions should be taken before dismantling.

3. Shipment inspection

- 3.1 Pumps and aggregates are suitably secured for normal transport. Anyway when received, the shipment should be inspected immediately. Damages to the packaging or crating that may reveal content damages when unpacked should be reported to the carrier and possibly photographed.
- 3.2 A photograph is helpful in any claims to be made against the carrier. The manufacturer or the local authorized distributor should also be informed.
- 3.3 If the shipment is not equal to the transport document, inform the carrier immediately.

- Original -

- 3.4 Check the nameplate data with the shipping papers and with your purchase order to ensure that the proper pump is provided.

4. Transport

- 4.1 The pump is equipped with a trailer designed for a speed up to 10 km/h. See the national regulations for movement on public roads.
- 4.2 The pump can be lifted with a lifting hook. Use the loop hole clearly marked for this purpose. The hole is designed to lift the pump and the trailer. Any third products must be removed before lifting the pump.

WARNING Never move or lift the pump while it being in operation or with connected lines.



Loop hole to lift the pump

5. Storage

- 5.1 If the pump is not used immediately after the receipt, it should be packed again and stored in an appropriate location.
- 5.2 Protective coatings on unpainted surfaces should be inspected to see if still intact. Unpainted surfaces, not factory treated with a rust inhibiting coating, should have a protective coating applied.
- 5.3 Plastic or gasket type port covers should not be removed.
- 5.4 Pumps should be stored in a clean and dry location otherwise protect them with a moisture repellent cover.
- 5.5 If the pump has been used, please empty the pump casing by opening the clean-out cover or plug and fill with some corrosion inhibiting oil.
- 5.6 Follow the motor instructions for the motor engine.

WARNING During cold weather never forget water inside pump casing! Water may freeze and break the pump casing!

- Original -

C. Description

Contractor pumps type S

1. Advantages

- 1.1 Self-priming centrifugal pumps with engine.
- 1.2 Self-priming: no need to fill pipes and hoses.
- 1.3 Casing made of cast iron or stainless steel with a large plug to clean, fill and drain it.
- 1.4 Wear-resistant open impeller with easy replaceable wear plate(s). Low maintenance.
- 1.5 Shaft seal with mechanical seal on stainless steel shaft sleeve with grease lubrication. More protection on dry running condition.

2. Options

- 2.1 Pump on trailer with fuel tank frame and tractor-profile wheels for 10 km/h.
- 2.2 Pump on base frame with fuel tank for fixed installation or for trailers.
- 2.3 Pump on base frame with fuel tank and skid.
- 2.4 Pump on base frame with fuel tank, skid and roll bar.
- 2.5 Drain valve for pump casing.
- 2.6 90° curve for the discharge side with quick couplings.
- 2.7 Special paint, 2K epoxy prime coat, 2K polyurethane finish coat.
- 2.8 10", 13" or 17" tractor-profile wheels.
- 2.9 Fuel tanks of different sizes.
- 2.10 Fuel level indicator.
- 2.11 Inspection cover with stainless steel eyebolts.
- 2.12 4 loop holes for safe transport.
- 2.13 Tank cover with integrated air-release valve.
- 2.14 Removable filter in the fuel tank filler neck.
- 2.15 Detachable tow bar with tow hitch.
- 2.16 Wheel chocks.
- 2.17 Toolbox (with or without tools).
- 2.18 Battery-holder with battery mounted on vibration dampers.
- 2.19 Control panel with hour meter, oil temperature, charging light, head oil temperature, oil pressure.
- 2.20 12V power connector (according to NATO standards).
- 2.21 LED lamp.
- 2.22 Integrated battery charger.

D. Operation

1. Installation

- 1.1 Set up the pump on a level surface as near as possible to the liquid to be pumped. Make sure that the surrounding is adequately ventilated.
- 1.2 Suction hose or pipe should be as short as possible and should have the same diameter as the pump port. It is recommended to prevent any bends, elbows and narrow points. This will reduce the priming time and ensure full capacity.
- 1.3 Check that any connections (threads, welds, gaskets, quick-couplings, valves, etc.) are completely airtight: if necessary, coat them with grease.
- 1.4 It is advised to use a non-return valve (available on request).

2. First start-up

- 2.1 Use the pump only in the authorized performance levels indicated in performance curve, technical datasheet and this instruction manual! The liquid should never be pumped on the limit of vaporization, crystallization, polymerization or solidification.
- 2.2 The material of the pump must be compatible with the pumped liquid. The pump manufacturer has no responsibility on this.
- 2.3 Fill the fuel tank with regular fuel. The engine is not suitable for biodiesel.
- 2.4 To self-prime the first time: open the cover on the top of the pump casing. Fill the pump completely with the liquid to be pumped and close it.
- 2.5 Open all valves. Otherwise the mechanical seal can be damaged.
- 2.6 Start the pump through the ignition key on the panel and check after a couple of minutes if the pump is working as planned. If the aggregate reaches a noise level more than 100 LWA then you have to wear "hearing protection".

<p>WARNING Any deviation from normal operating conditions (increased power consumption, temperature, vibrations, noise etc.) or warning signals by monitoring equipment suggest a malfunction. Inform the responsible maintenance personnel at once to prevent the disturbance from getting worse and causing, direct or indirect, serious physical injury or material damage. In case of doubt disconnect the machine immediately!</p>

- 2.7 To stop the engine, turn the ignition key to 0. Some engines have a lever to stop the pump. Please check this in the engine instructions.

3. Running

- 3.1 Start and stop the pump if necessary. The pump is designed for 6 starts per hour. More frequent start cycles must be approved by the pump producer.
- 3.2 If the suction line is empty, the pump will first suck in the air and then the liquid.
- 3.3 In case of pump stop, the integrated non-return valve prevents the liquid to flow back.

4. Operating troubles

- 4.1 PUMP DOES NOT PRIME
 - (a) Air leaks into the suction line (through couplings, threads, flanges, gaskets, hose clips, cuts, etc.). This error is hard to find. You can take off the suction pipe from the suction port, start the pump and check if the pump sucks by placing the hand on the suction port.
 - (b) Level of liquid inside pump casing is too low or empty.
 - (c) Low rotation speed.
 - (d) Overpressure in the delivery line. Air does not escape. Drain air through priming cover or install an automatic air-release valve.
 - (e) Liquid inside pump chamber is overheated. Allow liquid to cool down or refill it with cold liquid.

- Original -

- (f) Air leaks through the mechanical seal because of damage or lack of lubrication. Replace the mechanical seal.
- (g) Leading edge of the volute is worn out by the abrasive action of the liquid.
- (h) Clogged, broken or worn impeller.

4.2 LOW CAPACITY

- (a) Strainer or filter is clogged. Clean out.
- (b) Suction or delivery lines clogged or rubber hose collapsed. Locate and remove obstruction.
- (c) High friction losses in the line. Get rid of unnecessary elbows, valves and narrow points.
- (d) Static suction lift too high. Place the pump as close as possible to the surface of liquid to be pumped.
- (e) Low rotation speed.
- (f) Impeller clogged. Free impeller through the inspection cover or open the pump casing.
- (g) Impeller and/or wear plate(s) worn out. Replace.

4.3 PUMP IS MAKING NOISE

- (a) Discharge side or suction side closed or clogged. Check the piping. The installation of manometer and vacuum meter can be helpful.
- (b) Impeller clogged. Free impeller through the inspection cover or open the pump casing.
- (c) Cavitation. The pump is working outside the allowable curve. Check how the sound changes by slowly closing and opening the valve in the discharge side or reduce the speed.

4.4 PUMP IS LEAKING

- (a) Loosen screws. Check
- (b) Tension on the pump and piping to high. Check.
- (c) Overpressure. Mechanical seal damaged.
- (d) Dry-running or closed lines. Mechanical seal overheated and broken. Replace.
- (e) Rubber components not compatible with the pumped liquid. Please contact your pump partner for alternatives materials.

4.5 For any other operation troubles, please contact your pump partner by mentioning:

- ⇒ Pump type
- ⇒ Serial no.
- ⇒ Problem
- ⇒ Running time
- ⇒ And possibly attach photographs of pump and piping.

5. Warranty

- 5.1 The manufacturer warrants the pump against defects or faulty workmanship for a period of 24 months from the date of delivery. Longer warranty periods are available on request.
- 5.2 Repair of the pump or replacement of parts or of the pump itself can only be carried out after careful examination of the pump in our workshop where the pump should be sent by carriage paid. Any exceptions must be confirmed in writing.
- 5.3 This warranty does not cover parts damaged by improper operation, handling and assembly, as well as parts subjected to deterioration and normal wear (especially impellers, wear plates and mechanical seals).
- 5.4 This warranty is no longer valid if the pump is disassembled or modified without the authorization of the manufacturer.

WARNING During cold weather never forget water inside pump casing! Water may freeze and break the pump casing!

6. Maintenance

- 6.1 After start-up the pump will need to be checked at the following intervals to make sure it is pumping properly and with regard to pump noise: 10 min. / 1 hour / 10 hours.

WARNING Never forget water inside pump casing during cold weather! Water may freeze and break the pump casing!

- 6.2 Each 3 months, if necessary, lubricate the mechanical seal (see section D.7 "Lubrication of the seal" on page 8).
- 6.3 Each 6 months open the inspection cover or the casing and check inside. Remove possible foreign parts blocked inside the casing. Clean the pump and the motor. If necessary, check more frequently.
- 6.4 Each 5-10 years make a general pump recondition.

7. Lubrication of the seal

- 7.1 To avoid the dry running of mechanical seal type .12. and .31., a grease chamber is provided. This must be refilled from time to time with little of grease. For all other seals this is not provided.
- 7.2 A grease nipple is mounted on the head of the pump. This does not need maintenance for the first 1000 hours of work. Then the mechanical seal must be lubricated through the grease nipple every 800 hours with a maximum of 1 hub of grease. Use a commercially available grease with viscosity grade from 1 to 3.

WARNING Do not over-grease, otherwise the engine can get damaged!

The logo consists of the word "BEDU" in a large, bold, white sans-serif font, with "POMPEN" in a smaller, white sans-serif font below it. The text is centered within a dark teal square, which is itself centered within a white square border.

BEDU
POMPEN

made for your process

- Expert advice
- A customer-oriented organization that adapts to the requirements and wishes of your organization
- Innovative and customized solutions
- Breakdownservice, 24 hours a day, 7 days a week
- Technical service with extensive test facilities, working from our own workplace or at your location
- A fast and appropriate solution for all your issues
- Wide range of liquid pumps
- Repair, maintenance and revision

BEDU POMPEN B.V.
Poort van Midden Gelderland Rood 10
6666 LT HETEREN
Nederland
Telefoon +31 (0)88 4802 900
E-mail sales@bedu.eu

WWW.BEDU.NL

BEDU BELGIUM B.V.B.A.
Industriepark-West 75
9100 SINT-NIKLAAS
België
Telefoon +32 (0)3 80 87 980
E-mail sales@bedu.eu

WWW.BEDU.BE

