

BEDU
≡ POMPEN ≡

**OPERATING AND MAINTENANCE
MANUAL**



**Gear Pumps
F-FM-FT series**

made for your process

1. GENERAL INFORMATION

- 1.1 SUPPLY CONDITIONS
- 1.2 MANUFACTURER
- 1.3 USER MANUAL CONTENT
- 1.4 NAME, TYPE
- 1.5 NOISE EMISSIONS
- 1.6 APPLICATION FIELDS AND LIMITS. ALLOWED AND NOT ALLOWED USES

2. TRANSPORT, HANDLING, PACKAGING, STORAGE

- 2.1 GENERAL
- 2.2 MOVING AND LIFTING
- 2.3 STORAGE FOR LONG PERIOD

3. DESCRIPTION OF THE PUMP AND THE PUMP UNIT

- 3.1 GENERAL DESCRIPTION OF THE MACHINE
- 3.2 WARNINGS
- 3.3 PROTECTION DEVICE
- 3.4 ADDITIONAL DESCRIPTION OF ACCESSORIES
 - 3.4.1 Seal parts
 - 3.4.2 Safety valve

4. INSTALLATION, ASSEMBLY

- 4.1 SPECIAL ASSEMBLY TOOLS
 - 4.2 INSTALLATION SITE INFORMATION
 - 4.2.1 Space requirements for operation and installation
 - 4.2.2 Inspection before starting installation
 - 4.2.3 Foundation details
 - 4.2.4 Alignment requirements
 - 4.2.5 Suction lift
 - 4.3 INITIAL INSTALLATION
 - 4.3.1 Complete Pump Unit
 - 4.3.2 Bare shaft pump
 - 4.4 DRIVE UNIT AND ACCESSORY ASSEMBLY
 - 4.4.1 Motor
 - 4.4.2 Installation of safety and control devices
 - 4.5 ELECTRICAL CONNECTIONS, CONNECTION CABLES
 - 4.6 PIPING
 - 4.6.1 General
 - 4.6.2 Forces and moments which operate on suction and delivery flanges.
 - 4.6.3 Fastening screw torques
-

5. COMMISSIONING, OPERATION, SHUTDOWN

- 5.1 DOCUMENTATION
- 5.2 PUMP PREPARATION FOR STARTUP
 - 5.2.1 Filling / discharge
 - 5.2.2 Electrical connections
 - 5.2.3 Verifying the direction of rotation
- 5.3 SAFETY DEVICES
 - 5.3.1 Mechanical safety devices (guards for rotating parts)
 - 5.3.2 Acoustic insulation
 - 5.3.3 Splash-proof cover
 - 5.3.4 Regulation on the electric components
- 5.4 COMMISSIONING
 - 5.4.1 Initial commissioning
 - 5.4.2 Startup after shutdowns
 - 5.4.3 Pump system requirements
 - 5.4.4 Startup/shutdown frequency
 - 5.4.5 Operation and startup with closed valve
- 5.5 SHUTDOWN
 - 5.5.1 Decommissioning
 - 5.5.2 Emptying

6. MAINTENANCE AND INSPECTION

- 6.1 USE PRECAUTIONS
- 6.2 WEARABLE MATERIALS
- 6.3 SURVEILLANCE DURING OPERATION
- 6.4 PREVENTIVE MAINTENANCE
- 6.5 PUMP DISASSEMBLY AND REASSEMBLY
 - 6.5.1 Tools
 - 6.5.2 Disassembly/reassembly procedure

7. FAULTS: CAUSES AND SOLUTIONS

8. WARRANTY CONDITIONS

9. ALLEGATI/ANNEXES

1. GENERAL INFORMATION

1.1 SUPPLY CONDITIONS

According to agreements with the Customer, the pump can be supplied either as bare shaft or pump unit. By pump unit we mean the pump coupled with the motor, including reduction gears and/or speed variators, if any. The coupling can be direct (FM or FT series) or through bell housing (F series).



1.2 MANUFACTURER

The pump Manufacturer is Bedu Pompen B.V. You can apply for assistance by sending a request to the following address:

<p>Bedu Pompen B.V. Poort van Midden Gelderland Rood 10 6666 LT HETEREN, The Netherlands Tel:+31 (0)88 4802 900 - Fax:+31 (0)88 4802 901 Email: sales@bedu.nl</p>
--

1.3 USER MANUAL CONTENT

This user manual provides all the necessary information to ensure a safe and correct use of the machine. It was written – when applicable – according to point 1.7.4 of Directive 2006/42/EC, to point 6.4.5 of Standard EN ISO 12100:2010 - Machinery Safety and according to point 7.2 of Standard UNI EN 809:2010 - Pumps and Pump Units for Liquids - Common Safety Requirements -. In this manual it is constantly referred to safety instructions. Such instructions are identified by the following symbols:

	It represents the safety instructions contained in this manual, whose non-observance may compromise safety.
	It is shown when electrical safety is essential to worker protection.
	It indicates the safety instructions which should be taken into account for the safe operation of either the pump, the pump unit or the pump or pump unit protection.

1.4 NAME, TYPE

The pump standard execution is that with cast iron body, gears and shafts in carbon steel, with self-lubricating bushes made of sintered bronze and P.T.F.E. and ceramic/graphite/FPM mechanical seal. The complete series covers different executions (body and gears in bronze or in AISI 316 stainless steel, with shafts in AISI 316) and different capacities. Moreover, executions with pre-heating chambers and special mechanic seal are also provided. The pump identification is realized through an alphanumeric code (see the following example):

- 00FG015/WECD00 : pump type F, cast iron execution, rated capacity 15 l/min. at 1500 rpm, gears and shafts made of carbon steel, standard mechanical seal, equipped with brass safety valve, with bell housing for coupling with a Size 80 motor.

1.5 NOISE EMISSIONS

- Reference standard: EN ISO 2361:2015 and UNI EN ISO 3744:2010.

- Measured values:

- 1 - Equivalent weighted continuous acoustic pressure level
Leq = 80 dB(A);
- 2 - Maximum weighted instantaneous acoustic pressure
C (peak level) Lpc < 82 dB(C).

- Test conditions: When measuring noise, the pumped liquid (ref. to oil with 30 cP viscosity) must be introduced into the testing system at a speed of less than 0.8 m/s into pipes. It must however reach laminar flow regime (thus the speed must be related to the viscosity) and the conditions outlined in this manual must be respected.

1.6 APPLICATION FIELDS AND LIMITS. ALLOWED AND NOT ALLOWED USES

Each machine shall be used according to the type of application, operating conditions and liquid characteristics provided in contract specifications. Each variation which alters the intended use of the pump is forbidden and the User is fully responsible for it (e.g. the use of a liquid which is corrosive to pump materials rather than the recommended fluid, etc.). For variations in use within the application limits (e.g. fluid viscosity variations) it is advised to contact the Manufacturer in advance.



Max. working pressure, for pumps in standard execution, is 15 bar.

In any case, the use of “KK” or alike plastic gears to allow the pump to operate also with poorly lubricating fluids, requires greater attention to avoid excessive or unexpected pressure loads.



It is absolutely forbidden to use the machine in hazardous environments (explosive atmosphere, etc...), the use of hazardous substances (e.g. fluids with dangerous gases), in critical conditions (e.g. abnormal temperatures, etc...), which are not supplied with the pump.



For pumps and pump units intended to be used in potentially explosive environments, please read carefully “Additional instructions for the operation and management of pumps and pump units intended to be used in potentially explosive atmospheres (Directive 2014/34/EU)”.



Bedu Pompen B.V. declines every responsibility for the consequences arising from an improper use of the machine which does not comply with what prescribed in this manual or specifically requested when ordering.

2. TRANSPORT, HANDLING, PACKAGING, STORAGE

2.1 GENERAL

Bedu Pompen sells “ex works”. Consequently, transport from the manufacturing shop to the named place of destination is carried out by the Customer under his own responsibility. For each transport a suitable standard packaging is ensured or established based on Customer requirements who, in any case, must give information about the type of shipment to be performed (by land, air, “overseas”).

In case of long stationary periods under critical environmental conditions (such as: high humidity and/or salinity, etc.) the supply shall be stored in a protected environment.

2.2 MOVING AND LIFTING

For lifting or moving the pump units', preferentially use the eye bolts, if any always choose slings or lifting bands suitable for the weight of the equipment to more or to lift.

The weight of the units indicated on the package and on the transport document.

Please find here below, some sample pictures showing different ways for lashing the pump unit.

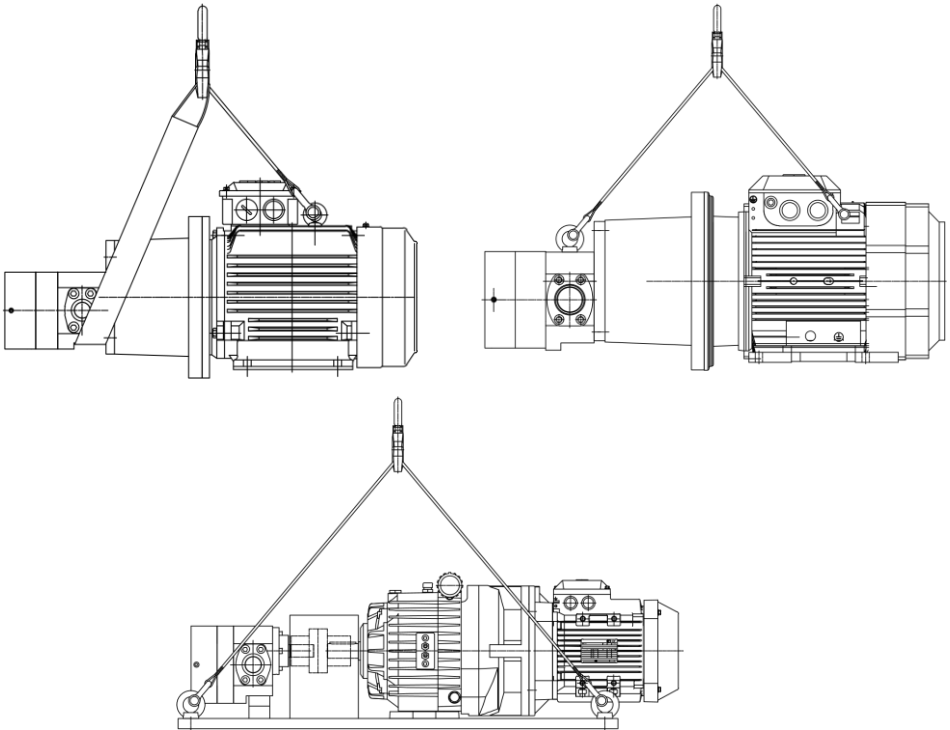

2.3 STORAGE FOR LONG PERIOD

As far as motors are concerned, please consult the operating and maintenance instructions of the Supplier.

Pumps must be stored indoors, in a clean, dry, moisture-free and vibration-less environment. Pump nozzles and other opening must be appropriately plugged and protected against dust entrance. Pumps must be emptied from the process liquid, eventually washed in case of aggressive fluids. Gears must be abundantly lubricated with glycerine oil (or other lubricant fluids, compatible with the pump materials). At lubricating interval and monthly, spin the pump shaft 2 turns, by hand. Before start-up, visually check for the pump unit integrity, verify the pump shaft turns freely by hand and check that all bolts and screws are correctly tightened.

3. DESCRIPTION OF THE PUMP AND THE PUMP UNIT

3.1 GENERAL DESCRIPTION OF THE MACHINE

Essentially the pump consists of two driven pinions which mesh one another inside a cast main body, thus creating a flow of liquid between the inlet and the outlet (*Fig.1*)

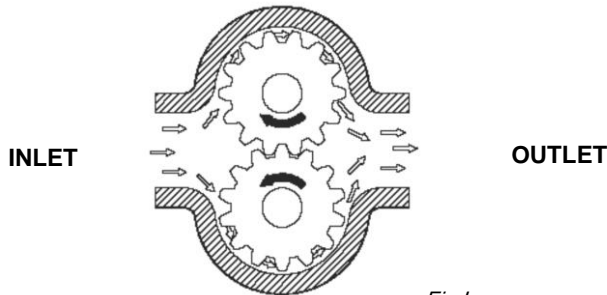

Fig.1

The fluid containment inside the pump is ensured by a suitable seal part as defined in the order.

Pumps, series FM and FT, enbloc, are directly coupled to the electric motor shaft, according to CE standards; pumps series F are connected to the motor (shape B34) by means of a flexible coupling and a bell housing, which also acts as safety coupling guard.

The pump unit series F can be equipped with a mechanic reduction gear or a hydraulic variator to adjust the rotation speed, according to CE standards.

3.2 WARNINGS

Standard construction pumps, as an indication, require a NPSH of approx. 0.4 bar. Always calculate the maximum available suction lift, in relation to fluid characteristics, suction circuit and operating conditions. Ensure that gears do not operate when dry. Before starting the pump for the first time or after long stationary periods, it is advisable to fill the gear spaces with oil or liquid being pumped through one of the nozzles and rotate the driving shaft by operating manually with a screwdriver on the motor cooling fan. This also makes it possible to check for even and smooth movement of rotary components and excessive friction. It is recommended that an overland cut-out set at approx. 10% above the motor current be installed in the control circuit.



In our pumps the direction of rotation is clearly shown by an arrow marking the right direction.

The pump operating temperature in normal working conditions is about 80°C. In special pump versions, working temperatures of 180°C and more may be achieved. To protect personnel from dangers due to the temperatures reached during the operation of the machine, in the event of accidental contact (burn), the User must reduce the external pump temperature by means of insulation plates, coatings, screens, barriers, etc. As limit reference temperature for the contact surface it is advisable to take 55°C. Below this value, for hot smooth surfaces in bare metal, there is no burn threshold. For a detailed knowledge of this problem in relation to different particular cases, the User can read the standard UNI EN ISO13732-1, where burn thresholds are specified for several types of surface according to the "surface temperature - contact time" parameters.



Liquids to be pumped must not contain abrasive or solid suspension as this will greatly reduce the pump life. At this purpose we recommend the installation of a properly sized filter on the suction line if solids may be present.

When pumps are installed in parallel, the suction lines should be adequately separated to prevent unnecessary turbulence.

3.3 PROTECTION DEVICE



The bell housing installed by the Manufacturer is made of an aluminium die-casting, fastened to the motor by screws, duly shaped to prevent fingers from coming into contact with moving parts. It can be removed only by using a proper tool.

3.4 ADDITIONAL DESCRIPTION OF ACCESSORIES

3.4.1 Seal parts

The pump is usually supplied equipped with mechanical seal. If the Customer requires a particular type of seal, Bedu Pompen installs the desired seal after verifying if its dimensions are compatible with those of the pump. In case the Customer requires only the seal mark, the Company leaves the Manufacturer to select the type of seal, by giving information about the pumped liquid.

3.4.2 Safety valve

The pump can be equipped with a safety valve, with adjustable calibration, installed on the rear cover.

After reaching the calibration pressure, prevailing on the contrast spring reaction, the valve starts opening by connecting the outlet side and the inlet side of the pump.

The valve function is just to protect the pump from accidental pressure peaks. Its prolonged opening may imply the pump damaging.



4. INSTALLATION, ASSEMBLY

4.1 SPECIAL ASSEMBLY TOOLS

To assemble the pump you do not need special tools, except for seal extractors (see Maintenance).

4.2 INSTALLATION SITE INFORMATION

4.2.1 Space requirements for operation and installation

The space destined by the Customer to the installation of the machine should be enough to gain access to, install and maintain the pump unit.

4.2.2 Inspection before starting installation

Before installation, the Customer must ensure that the environmental conditions of the selected site comply with requirements specified under the contract.

In particular, unless expressly required and accepted in the order, the installation site should not be exposed to the following environmental conditions:

- abnormal temperature;
- high humidity;
- corrosive atmosphere;
- explosion and/or fire hazard areas;
- dust, sandstorms;
- earthquakes and other similar external conditions;
- high level of vibrations;
- high altitude;
- flood hazard areas.



4.2.3 Foundation details



When the pump unit is installed, it shall be firmly fixed in place by fastening bolts or by using other securing methods.

Ground fastening bolts or other securing methods shall be of sufficient strength to prevent the pump unit from moving accidentally.

4.2.4 Alignment requirements



The alignment operation must not submit the pump unit to axial and radial stress, therefore the offset must always be lower than the tolerance limits expected for the coupling.

Leave always an axial clearance (about 2-3 mm) between the facing surfaces of the flexible couplings.

4.2.5 Suction lift



The suction lift, that is the vertical distance between the pump inlet mid-point and the free surface of the tank to which the pump is attached, must not exceed 5 m to allow pump priming and avoid cavitation phenomena (*Fig.11*).

Otherwise, contact our Technical Department.

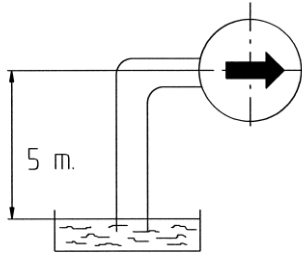

Fig.II

Each pump must have its own suction pipe; the installation of two or more pumps with a common suction pipe length causes the pump to work less efficiently (Fig.III).



The length of the suction pipe must be reduced as much as possible to minimize pressure losses in such segment; higher pressure losses in the discharge line do not adversely affect the correct operation of the pump (if they do not exceed the delivery limits stamped on rating plate).

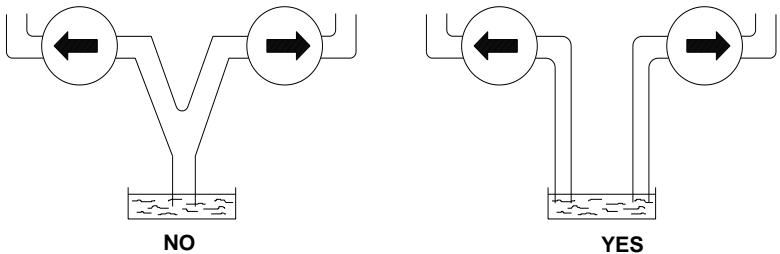

Fig.III



Furthermore, it is necessary to check that siphons are not created in the suction pipe, since the formation of air pockets generates vibrations and stresses which are not compatible with the correct operation of the pump and may obstruct the pump priming at startup (Fig.IV).

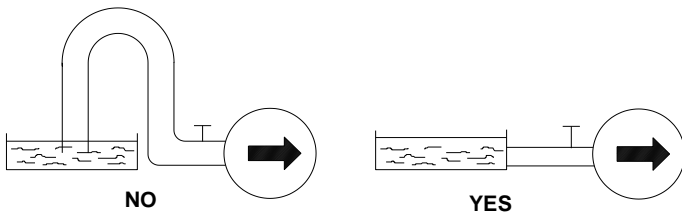

Fig.IV



In case of installation below head, the pump does not ensure to be able to intercept the flow of fluid as a shut-off cock or a proper stop valve.

4.3 INITIAL INSTALLATION

According to the conditions of supply, the pump can be delivered as follows:

4.3.1 Complete Pump Unit



In this case the Customer must stiffly fasten the pump unit in order to ensure the correct axis alignment in all operating conditions.

We recommend the use of vibration dampers below the motor feet and vibration damping sections on pipes near pump inlets.

Once the pump unit has been positioned, proceed as described below:

- a) connect suction and discharge pipes respectively to the pump inlet and outlet;
- b) power the motor, by carefully controlling the compatibility of motor voltage and frequency with those of the system;
- c) open the intake and discharge pipe valves, if any;
- d) run the motor for a while to verify that the pump rotates in the direction indicated by the arrow stamped on the pump.

4.3.2 Bare shaft pump

In this case, before following the steps described at Paragraph 4.3.1, choose the type of motor and align it to the pump.



The motor must be selected by the Customer depending on the type of operation for which it is specifically requested (continuous operation, discontinuous operation, repeated startups, indoor or outdoor installation, explosive atmosphere, critical environmental conditions, altitude, etc.) with power compatible with that required by the pump.

Motor and pump shafts are coupled by flexible coupling. The aluminium bell housing, with centerings both on pump and motor, guarantees a correct alignment.



Leave always at least 2-3 mm axial clearance between the couplings.
Do not move the pump side coupling; operate on the motor side coupling only.

4.4 DRIVE UNIT AND ACCESSORY ASSEMBLY

4.4.1 Motor

The Company installs EC approved electric motors, of power compatible with that required by the pump, selected according to the desired operating conditions and environmental characteristics. In particular if the pump unit is required to operate in explosive atmosphere, the motor is chosen in explosion-proof execution (**we remind that, to be used within the European Union, also the execution of the pump and the relevant fittings must comply with directive 2014/34/EU**).



4.4.2 Installation of safety and control devices

If specifically requested in the order form, the Company provides the relief valve, which must be calibrated to protect the pump from damage. Once it has been properly calibrated, the valve must not be tampered with in any way, since volumetric pumps can reach quickly, with the delivery closed, extremely high pressure values, with consequent very serious danger.



Any pressure adjustment shall be compulsorily made with the pump stopped and depressurized.



The User shall install a pressure gauge in the pump outlet; it is advisable to install a vacuum gauge near the pump inlet.



In case also a regulating valve is installed on the system, make sure that the calibration pressure differs considerably from the safety pressure not to generate dangerous resonance phenomena (pipe and/or valve break).

4.5 ELECTRICAL CONNECTIONS, CONNECTION CABLES

The machine shall be connected to the external ground protection system by the appropriate terminal, which must be identified by the PE letter. Connection cables shall be properly sized and insulated. Before energizing the machine, always verify that the mains voltage and frequency are compatible with those of the motor.



4.6 PIPING

4.6.1 General

Pipes shall have a suitable diameter to allow a regular flow with low pressure losses. Therefore, we recommend to use, at least for the suction line, pipes with inner diameter equal to or greater than that of the pump inlet, mostly when the viscosity level becomes considerable. To minimize pressure losses in the circuit, we recommend to avoid, as much as possible, abrupt variations of section and direction (curves) along the pipe run, particularly in the suction line.



4.6.2 Forces and moments which operate on suction and delivery flanges.

As general rule it would be necessary to interpose flexible vibration damping sections between the pump and the system piping; therefore, we recommend to verify that the flanges of the connection pipes are always placed, in free position, with the planes parallel to those of the flanges of the suction and delivery nozzles to avoid that, after fastening them, forces and moments of excessive value are generated.



In any case, the User shall make sure that the loads induced on the pump flanges, under the most critical operating conditions, do not exceed the values prescribed by Standards UNI EN ISO 14847:1999.

4.6.3 Fastening screw torques

The fastening torque for the screws of our pumps shall be:



- for M6 screws 11-12 Nm
- for M8 screws 20-22 Nm
- for M10 screws 38-40 Nm

For more detailed information, contact our Technical Department.

5. COMMISSIONING, OPERATION, SHUTDOWN

5.1 DOCUMENTATION

Operating and maintenance manual

5.2 PUMP PREPARATION FOR STARTUP

5.2.1 Filling / discharge

To prevent gears from running dry, before starting the pump for the first time or after long stationary periods it is advisable to fill the gear spaces with oil or liquid being pumped through one of the nozzles and rotate the driving shaft by operating manually with a screw-driver on the motor cooling fan. This also makes it possible to check for even and smooth movement of rotary components and excessive friction.



The pump discharge, in case of toxic, noxious or, in any case, dangerous fluid, shall take place according to all the necessary cautions. In particular, the pump body shall be emptied according to proper operating maneuvers.



5.2.2 Electrical connections

It is necessary to choose wires which satisfy the operating conditions required by the Customer (e.g. voltage, current, electric shock protection, bundle of cables) and can support external influences (e.g. ambient temperature, presence of water or corrosive substances, mechanical stresses, fire hazards). Moreover, we remind that wires must be properly sized to ensure the voltage drop from the power supply inlet to the point of load application does not exceed 4%.



5.2.3 Verifying the direction of rotation

Open the intake and discharge valves. To verify the direction of rotation run the motor for a while only to check that the pump rotates in the direction marked by the arrows.



5.3 SAFETY DEVICES

5.3.1 Mechanical safety devices (guards for rotating parts)

The hazardous area, represented by the projecting sections of pump side and motor side shafts and the coupling, shall be protected against accidental contact using bell housing, which must be firmly secured both to the motor and to the pump.



5.3.2 Acoustic insulation



Sound emission values are specified in this manual. The User should always verify if the regulations of his own country prescribe, in relation to the frequency of exposure to emission values, the use of **individual protection devices**. If it is, he must comply with the requirements contained in the above-mentioned regulations to protect the operator's health and safety.

5.3.3 Splash-proof cover



In the event the liquid being pumped is dangerous, the operator must be in any case protected against the risk of any accidental contact with jets of liquid by wearing appropriate **individual protection devices**.

5.3.4 Regulation on the electric components



We remind that in accordance with Standard IEC 60204-1 Ed.2000-05, as power disconnecting switch, a plug/socket combination is allowed for a machine with rated power **equal to or lower than 16 A** and a total power **equal to or lower than 3 kW**.

5.4 COMMISSIONING

5.4.1 Initial commissioning



- Ensure that the pump unit is properly earthed.
- In case the pump is equipped with preheating chamber, it is necessary to operate this last up to reach the normal operating temperature and gradually start the liquid pumping up to reach the operating conditions in thermal equilibrium.



- Verify that suction pipes are properly joined one another to avoid air infiltrations which would prevent the pump from priming.



- Check that siphons are not created in the suction pipes so that pump can completely remove the air. In this case, if the air is not completely removed then the flow rate may decrease and the noise level may increase although the pump has taken in the liquid, with consequent premature deterioration of bearing bushes and moving parts.

- Verify the proper operation of the relief valve; to do so it is necessary to gradually increase pressure, by acting on the valve located on the discharge pipe, up to reach the expected calibration value. Now, after a further rotation of the valve, the discharge pressure shall remain lower than the calibration value. Otherwise, **after stopping the machine and depressurizing the pump**, it is necessary to disassemble the valve cap (16), remove the gasket below (18), loosen the nut (19) and rotate counterclockwise the spring (20) pre-load adjusting screw (17) (clockwise to increase the pre-load). Retighten the lock nut (19), interpose the gasket (18) and rescrew the protection cap (16). **The adjusting screw (17) is not equipped with retainer, therefore it is necessary to pay attention, when unscrewing it, not to cause a leakage of the fluid being pumped.**



5.4.2 Startup after shutdowns



The most common case in which the pump may stop working - apart from the power supply failure (black out) - is when the electric motor overcharge protection comes into operation. In this case, before starting the pump examine the causes which triggered the activation of the protection and remove them.

5.4.3 Pump system requirements



In volumetric pumps, pressure is not related to flow rate and/or rotation speed; therefore, avoid installing shut-off valves on the discharge pipe and, in any case, between the pump and the stop valve a relief valve must always be installed.

5.4.4 Startup/shutdown frequency

Pumps which are expressly requested by the Customer to start frequently and repeatedly do not show any problems for this kind of operation.

5.4.5 Operation and startup with closed valve



It is forbidden to start the pump with the discharge valve closed: such mistake would cause an abrupt pressure rise above the limit values with consequent seizing.

5.5 SHUTDOWN

5.5.1 Decommissioning



In case of decommissioning of the pump unit, it is necessary to disconnect the power supply to make unexpected and accidental startups impossible.

5.5.2 Emptying



A pump or a pump unit which operates with a flammable, toxic, corrosive or, in any way, hazardous fluid, or with a liquid at a temperature higher than 55°C, shall be equipped with a device such as a connection pipe, **to be provided by the User**, to collect and dispose the liquid drained or coming from any possible leakage from the shaft seal or discharged by a pressure relief valve.

6. MAINTENANCE AND INSPECTION



Maintenance operations and pump disassembly must be performed only by authorized and specifically trained people.

6.1 USE PRECAUTIONS

Before performing any maintenance operation, please observe the following safety precautions:



- **Never** execute maintenance operations with the pump running.
- Cut the power supply to the pump unit.
- Wear gloves, glasses, shoes and protective suits adequate to the characteristics of the liquid being pumped.



- Wait until the pump is cooled.
- **Never** open the pump unit and/or the relief valve when the pump is pressurized.



- Close suction and discharge pipe valves, if any.
- Disconnect the pump from suction and discharge pipes, by paying attention to put a collecting basin for the pipe liquid.



- Cut the power supply to the motor and disconnect the earth cable.
 - Unscrew anchoring screws and remove the pump unit.
 - Disconnect the pump from the motor, **leaving the bell housing connected to the pump.**
 - Place a collecting basin for the pump liquid.
 - Perform the maintenance operation.
 - Carry out the pump-motor coupling carefully.
 - Secure the unit by anchoring screws.
 - Connect the pump to suction and discharge pipes.
-



- Reconnect the power supply to the motor and the earth cable.



- Open suction and discharge pipe valves, if any.
- Reconnect the power supply to the pump unit.

6.2 WEARABLE MATERIALS

The normal wear parts, included as spares in the 2-year warranty are the following:

- bearing bushes;
- seal parts (mechanical seal, gaskets);
- gears;
- shafts.

6.3 SURVEILLANCE DURING OPERATION

The pump unit does not need the presence of an Operator during the work cycle. It is up to the User to provide or not a periodic surveillance depending on the importance and seriousness of the operation. The relevant checks shall be aimed to detect abnormal noise, vibration, temperature levels and/or some dripping from the mechanical seals, variations of pressure and/or flow rate, etc.

6.4 PREVENTIVE MAINTENANCE

It is always advisable, for a reliable and cost-effective operation, to adopt a policy of preventive maintenance. The service time specified for wearable component parts in this manual can be used as reference for the first period of operation. Later the user will be able to improve the MTBM (Mean Time Between Maintenance) as a result of the acquired experience.



6.5 PUMP DISASSEMBLY AND REASSEMBLY

6.5.1 Tools

No special tools are requested, except for seal extractors.

6.5.2 Disassembly/reassembly procedure

Before disassembling the pump, it is necessary to perform the operations mentioned at point 6.1 "MAINTENANCE AND INSPECTION".



Refer to the drawings (Fig.1 e Fig.2) and nomenclature attached at the end of the manual.



After assembly, for the pumps provided with thrust bearing, it is necessary to pressurize the pump up to 5 ÷ 6 bar (alternatively, apply a traction of approx. 110 N to the drive shaft), put the pump side coupling near the bearing (if necessary, interposing the specific ring) and fasten it with the grub screw.

a) Access to the mechanical seal

In pumps series F (Fig.1), separate the spider bell housing from the motor and, after removing the key ① from its seat unscrew screws ① fastening the spider ③ to the pump body ① and remove the seal cover ②, without damaging the static part of the seal ⑤A, which is housed there. In this way, it is possible to check the wearing status of the seal contact surfaces. During re-assembly do not pinch the O-ring ⑫ housed in the seal cover.



In pumps series FM – FT (Fig.2), carry out the same operations as item e) and then unscrew the screws ① fastening the pump body ① to the motor and remove the conductor gear ④ and the tongue ③. After accurately detecting the ring ⑩ position, remove it after unscrewing the dowel ④. Remove gently the rotary part ⑭ of the mechanic seal and the seal cover ⑬ with the stationary ring ⑭A and the O-ring ⑫. It is possible to check the wearing status of the seal contact surface. During re-assembling, do not pinch the seal O-ring ⑫ housed in the seal cover. Grease the shaft and exert the helicoidal movement. Reposition the ring ⑩ correctly.



b) Replacing static seal

In pumps series F (Fig.1), to remove the static part of the seal ⑤ from the seal cover ②, it is necessary to extract, by using special pliers, the seeger ring ⑨ housed in the cover, remove the ball bearing ⑩ and exert a pressure upon the external side of the seal. After placing the seal cover on a plane and greasing the walls to make assembly easier, insert the new static seal with the relevant O-ring; use a pad interposed with a soft bearing to exert the force perpendicularly to the cover.



In pumps series FM – FT (Fig.2), remove the static part of the seal ⑭ from the seal cover ⑬ and replace it with a new one, without damaging the rubber sealing band.

c) Replacing dynamic seal

In pumps series F (Fig.1), to remove the dynamic part of the seal ⑤ it is advisable to use an iron wire bent at 90° at one end to hook the first or the second coil of the seal spring ⑤ B. Exert a traction force parallel to the shaft ⑩, by paying attention not to scratch this last. After greasing the shaft to make assembly easier, insert the new mechanical seal by rotating the spring in the direction opposite to that of the coil; use a pad interposed with soft bearing to press the seal up to make the spring ⑤B rest on the seeger ⑨ provided on the shaft.



In pumps series FM – FT (Fig.2) , carry out the same operations as item a).

d) Replacing bearing bushes

Carry out the same operations as indicated in items a), b), c), e). To replace the supporting bushes ④ and ⑥, bend them with a chisel or similar, paying attention not to damage the diameter of the bushing seats and remove them. Before inserting the new bushings, clean accurately the seat with alcohol to remove all impurities and wipe them very well. Insert the new bushings, which have to be slightly forced into their seats, to the stop beat. With regard to assembly, follow indications in items e), c), b), a).



e) Replacing gears and shafts

Carry out the same operations as indicated in items a), b), c). After marking the related position between the rear cover ② and the pump body ①, remove the socket head screws ⑦ fastening the cover and remove it, considering that the operation might be difficult because of the accuracy of shafts and dowel pins ②. Remove the duct shaft ⑨, remove any stop springs ⑩, remove the duct gear ⑧ from the shaft and remove the key ⑤; Carry out the same operation on the conductor shaft. During re-assembling, do not modify the position of the helicoidal tooth gears, in order not to reverse the axial thrust direction.





During re-assembly, carry out operations according to the opposite order and do not rotate the rear cover ② and do not pinch the O-ring ⑥ housed into it. Tighten the cover "cross" fastening screws ⑦ by rotating simultaneously the motor shaft, to avoid differentiated pressures on gears, which might increase frictions. With regard to tightening torques, see paragraph 4.6.3. Then carry out operations indicated in items c), a).

f) Safety valve replacement

Unscrew the cap ⑬ and remove the external sealing washer ⑭. Move the nut ⑰ and unscrew completely the adjusting ring nut ⑱, paying attention to the thrust exerted by the spring ⑳; disassemble the internal sealing washer ㉑.

Remove the spring ㉒ with the shutter assembled ㉓.

During re-assembly check the correct coupling between the shutter ㉔ and the seat obtained in the rear cover ② of the pump and replace both sealing washers ⑭.

7. FAULTS: CAUSES AND SOLUTIONS



Here below the most common causes of malfunctions in the operation of pumps are shortly listed together with the possible solutions.

FAULT		ORIGIN	CAUSE	SOLUTION
The pump does not start	Electrical	The motor is not powered	Verify electrical connections and thermal protections	
	Electrical	Incorrect supply voltage	Verify rating and type of (star - delta) motor connection	
	Electrical	Excessive power consumption	Reduce the inverter start ramp	
	Mechanical	Mechanical lock of motor and/or pump shafts	Verify that shafts rotate freely	
The pump does not suck liquid at startup	Electrical	Direction of rotation reversed	Reverse electric motor connections	
	Hydraulic	Valves on suction and/or discharge pipes closed	Open valves	
	Hydraulic	Suction filter clogged	Disassemble and clean the filter	
	Hydraulic	Presence of air in the suction pipe	Drain pipes. Remove siphons. Tighten fittings and flanges	
	Hydraulic	High pressure losses in the suction line	Increase the pipe diameter. Remove abrupt variations of section and direction	
	Hydraulic	Fluid too viscous	Preheat the fluid. Decrease the speed of rotation.	
	Pressure and/or flow rate pulses in the discharge line	Electrical	Overvoltage and/or overcurrent	Stabilize the mains voltage
		Electrical	Feedback electric circuit too sensitive	Stabilize the electric circuit
		Hydraulic	Feedback hydraulic circuit too sensitive	Increase the inertia of the hydraulic circuit
		Hydraulic	Presence of air in pipes	Drain pipes. Remove siphons. Tighten fittings and flanges
Hydraulic		Intermittent opening of the by-pass valve	Increase the valve operating pressure	
Hydraulic		Foot valve not working properly or of the type with plate and spring	Replace with free ball foot valve	

FAULT		ORIGIN	CAUSE	SOLUTION
The pump is noisy and vibrates	Hydraulic	Presence of air in pipes		Drain pipes. Remove siphons. Tighten fittings and flanges
	Hydraulic	Cavitation		Decrease pressure losses in the suction line. Reduce the speed of rotation. Change fluid temperature
	Mechanical	Ball bearing and/or bush failure		Replace ball bearing and/or bushes
The flow rate does not increase as the speed of rotation increases	Hydraulic	Pump saturation		Decrease pressure losses in pipes. Reduce fluid viscosity
	Hydraulic	Excessive speed of rotation in relation to the fluid viscosity		Decrease the speed of rotation or increase the fluid temperature
	Hydraulic	By-pass valve opening		Increase by-pass valve spring pre-load
	Hydraulic	Cavitation		Decrease pressure losses in the suction line. Change fluid temperature. Decrease speed of rotation.
Progressive reduction of the discharge flow rate and/or pressure, with constant speed of rotation	Hydraulic	By-pass valve opening		Increase by-pass valve spring pre-load
	Mechanical	Friction increase by thermal effect		Cool the fluid
	Mechanical	Gear shim adjustment to a given clearance gear		Grind rear cover
	Hydraulic	Decrease in viscosity due to the temperature increase		Decrease the fluid temperature

8. WARRANTY CONDITIONS

Bedu Pompen B.V. guarantees that pumps and pump units are free from defects in material, construction, workmanship and assembly for a period of 12 (twelve) months from the delivery date (specified on the D.D.T.).

The Purchaser's warranty is limited to the free replacement of parts, which are recognized faulty, by excluding the purchaser's right of requiring the contract cancellation or the price reduction or other damages.



Warranty is void in case of misuse or improper use of the pump by the User. The pump shall be used according to what expressly requested in the order or based on the instructions contained in this manual.

Any damages resulting from shocks and/or tampering are not covered by this warranty.

Warranty does not apply to normal wear parts and damages due to negligence and poor maintenance.

For the application of the warranty it is necessary that:

- the Customers immediately notifies Bedu Pompen the trouble he imputes to the pump;
- the pump was not tampered with;
- the pump is returned to Bedu Pompen clean, after removing any trace of the process fluid and in a proper packaging;
- the pump is equipped with its nameplate;
- a short description of the fault is provided in writing together with the operating parameters of the pump or the pump unit;
- if required, a chemical analysis or a sample of the process fluid is provided.



Pumps which have not been emptied of the process fluid or installations outside the pump unit will not be taken into account.

In the event Bedu Pompen acknowledges the defect under warranty, no charge will be made to the Customer both for the replaced material and the workmanship.

The forwarding charges from the Customer to Bedu Pompen B. remain to the Sender's (Customer) account.

9. ALLEGATI/ANNEXES



Le operazioni di manutenzione e lo smontaggio della pompa vanno effettuate unicamente da personale autorizzato e specificamente addestrato.

Maintenance operations and pump disassembly must be performed only by authorized and specifically trained people.

Gear Pump - F, FM, FT Series

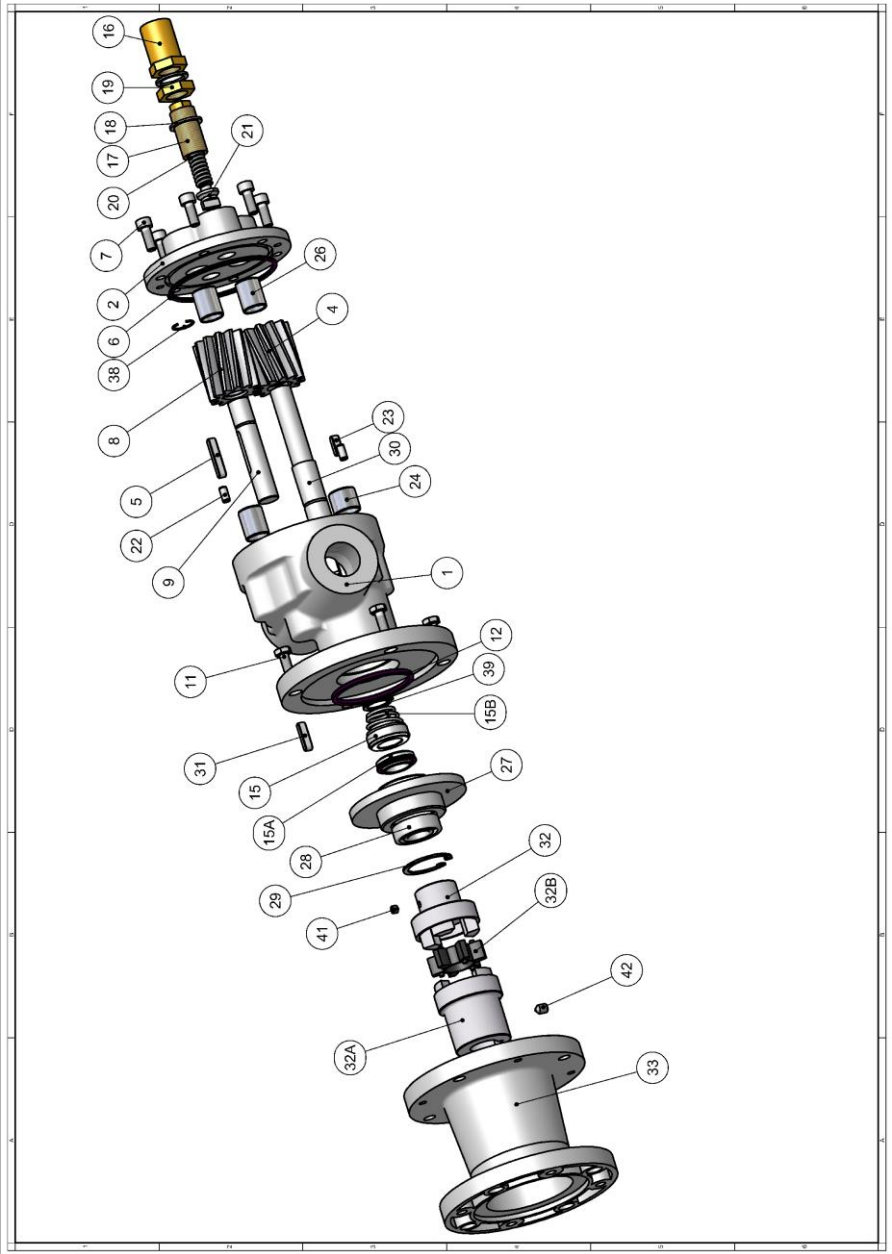

Figure 1

Parts list		
ITEM	Q.TY	DESCRIPTION
①	1	Main body
②	1	Back cover
④	1	Driving gear
⑤	1	Driven gear feather key
⑥	1	O-Ring
⑦	6	Socket screw
⑧	1	Driven gear
⑨	1	Driven shaft
⑪	4	Hexagonal head screw
⑫	1	O-Ring
⑮	1	Rotating ring (mech. seal)
⑯	1	Cap
⑰	1	Regulating screw
⑱	2	Washer
⑲	1	Nut
⑳	1	Valve spring
㉑	1	Valve shutter
㉒	2	Dowel pin
㉓	1	Driving gear feather key
㉔	1	Bush
㉖	3	Bush
㉗	1	Seal cover
㉘	1	Ball bearing
㉙	1	External retaining grid
㉚	1	Driving shaft
㉛	1	Feather key
㉜	1	Coupling (pump side)
㉝	1	Strainer
㉞	1	Spring clip
㉟	1	Internal retaining ring
㊱	1	Grub screw
㊲	1	Grub screw
⑮A	1	Stationary ring (mech. seal)
⑮B	1	Spring (mech. seal)
⑳A	1	Coupling (motor side)
⑳B	1	Spacer

Gear Pump - F, FM, FT Series

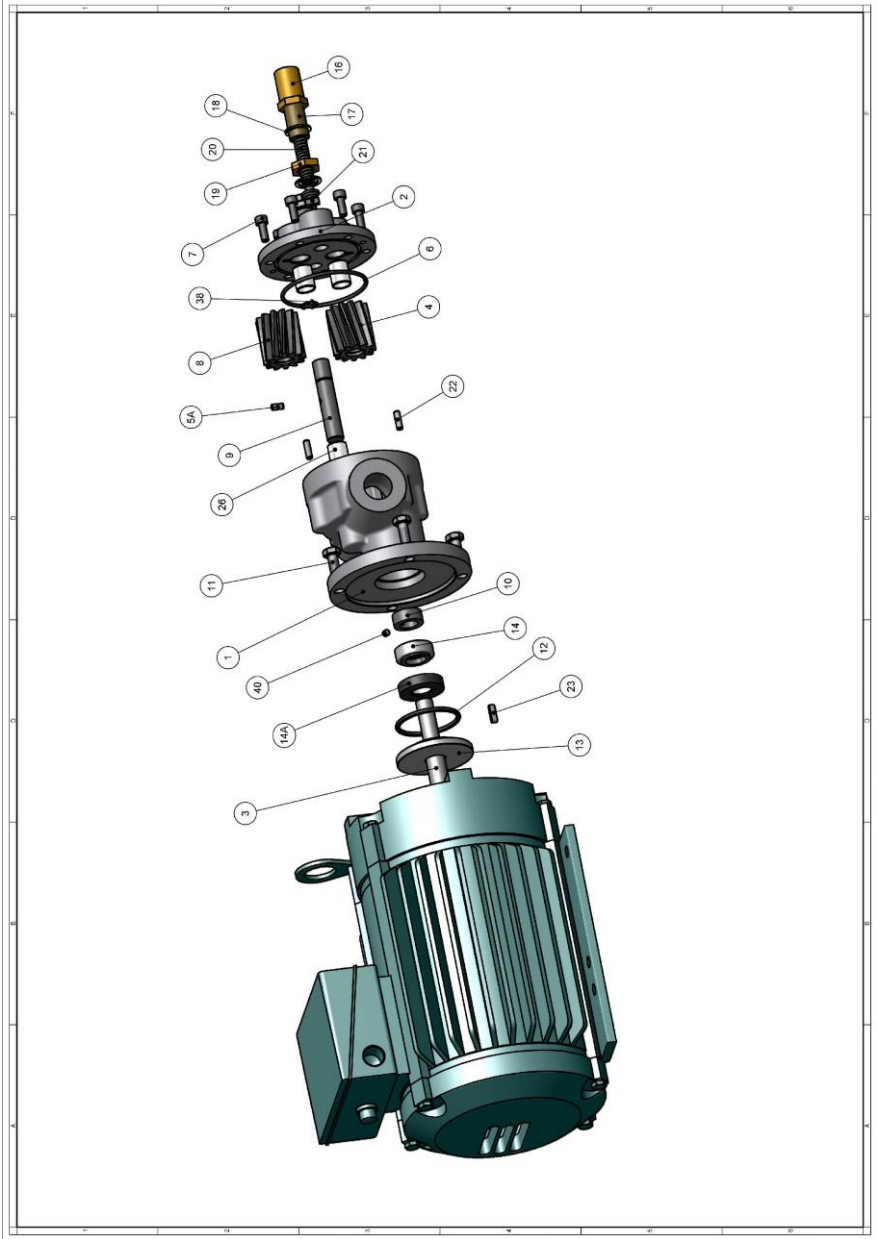

Figure 2

Parts list		
ITEM	Q.TY	DESCRIPTION
①	1	Main body
②	1	Back cover
③	1	Motor driving shaft
④	1	Driving gear
⑥	1	O-Ring
⑦	6	Socket screw
⑧	1	Driven gear
⑨	1	Driven shaft
⑩	1	Ring
⑪	4	Hexagonal head screw
⑫	1	O-ring
⑬	1	Seal cover
⑭	1	Rotating ring (mech. seal)
⑯	1	Cap
⑰	1	Regulating screw
⑱	2	Washer
⑲	1	Nut
⑳	1	Valve spring
㉑	1	Valve shutter
㉒	2	Pin
㉓	1	Driving gear feather key
㉔	3	Bush
㉕	1	Spring clip
㉖	1	Grub screw
⑤A	1	Dowel pin
⑭A	1	Stationary ring (mech. seal)

**Supplementary instructions for operation and maintenance of pumps and pumping sets
which work in potentially explosive atmospheres (Directive 2014/34/EU)**

Directive 2014/34/EU (that replaces Directive 94/9/EC, also known as ATEX), came into force on 30/04/2014 and concerns “equipments and protective systems intended for use in potentially explosive atmospheres”. Equipments and units intended for use in potentially explosive atmospheres are classified in groups and categories on the basis of the degree of safety they offer, so to their suitability to operate in locations with different classifications:

Group I (mines and related surface plants exposed to risk of re-release of firedamp and/or combustible dust)		Group II (other locations with potentially explosive atmospheres)					
Category M1 (very high protection level)	Category M2 (high protection level)	Category 1 (very high protection level)		Category 2 (high protection level)		Category 3 (normal protection level)	
		G (gas)	D (dust)	G (gas)	D (dust)	G (gas)	D (dust)
		Zone 0	Zone 20	Zone 1	Zone 21	Zone 2	Zone 22
		environments where explosive atmospheres are detected for long periods of time		environments where explosive atmospheres are probably detected		environments where explosive atmospheres are rarely detected and, however, for short periods of time	

For each zone, there are 6 classes of temperature, which have been stated depending on the minimum ignition temperature of the explosive mixture:

Temperature Class	Max. Surface Temperature
T1	450°C
T2	300°C
T3	200°C
T4	135°C
T5	100°C
T6	85°C

At the order, the Customer must define:

- working conditions of the pump (capacity, head, NPSH, local temperature,...);
- chemical and physical characteristics of fluid to be pumped;
- classification of dangerous area;
- temperature class.

Pumps cannot operate with working conditions different from the ones defined in the order, unless not expressly authorized and written by the Manufacturer.

PUMPS TYPE FG, FX, FZ

The marking of the pumps intended for use in potentially explosive atmospheres is as follows:

II 2 G c TX (or II 2 G c b TX)
and
II 3 G c TX (or II 3 G c b TX)

The first ones are classified as belonging to Group II, Category 2, with constructional safety **c** (eventually completed with **compulsory** monitoring of surface temperature **b**), for atmospheres with presence of gas, vapour or fog (**not dust**), suitable to be used in zones 1 and 2, with temperature class depending on the temperature of the pumped fluid (in any case not higher than T4).
The second ones are classified as belonging to Group II, Category 3, with constructional safety **c** (eventually completed with **compulsory** monitoring of surface temperature **b**), for atmospheres with presence of gas, vapour or fog (**not dust**), suitable to be used in zone 2, with temperature class depending on the temperature of the pumped fluid (in any case not higher than T4).

Users must check the pump so that it always works within the foreseen operating parameters. Local temperature range for operation is from -20°C to +40°C.

The symbol "TX" depending on the max temperature of the pumped fluid, indicates the Temperature Class, according to the following table:

Max. Fluid Temperature	Temperature Class
80°C	T4
140°C	T3
230°C	T2
300°C	T1

For operating in a defined temperature class with fluids that have higher temperatures than the ones written in the table above, or however with dangerous fluids, pumps must necessarily be equipped with special devices for continuous checking of the surface temperatures near the mechanical seal chamber. **The outlet electric signals must be transmitted to a processing unit for continuous monitoring and for shutting off the pump with a safety margin of at least 20°C with respect to the max. surface temperature of the relevant temperature class.**

In standard executions, the max. differential pressure of the pumps is 10 bar; the max. outlet pressure is 12 bar. In particular conditions such limits can be raised up by the Manufacturer; however, such values are marked on the nameplate of the pumps.

The rotation speed of pumps shall not exceed the value stated in the order, unless not expressly authorized and written by the Manufacturer; in no case, however, it will exceed 1750 rpm.

We remind you that every protection device, safety component and safety, control and regulating device installed by the Customer, must be in accordance with requirements of the directive 2014/34/EU(ATEX).

If you have any doubt concerning the operation limits of the pump, please contact:

Bedu Pompen B.V.
Poort van Midden Gelderland Rood 10
6666 LT HETEREN, The Netherlands
e-mail: sales@bedu.nl

PRELIMINARY REMARK

ATTENTION

Here below we will also briefly outline some advice which, even if it does not directly concern the pump and/or the pump unit, nevertheless can affect, sometimes significantly, its right operation.

It is clear that the Manufacturer neither can foresee the numberless possible applications in which pumps can be involved, nor can take into account, in particularly complicated installations, all the possible interactions that the malfunction of any component can have on the pump operation. The User, on the basis of the information given by the Manufacturers of the single components (or of the sub-assemblies) shall however carry out a careful assessment of the **plant risks** and take the proper further safety measures where they need.

WARNINGS

ATTENTION

All operations concerning installation, commissioning and maintenance must be done by expert personnel authorized by the Customer to work on such equipments. It is Customer's care, on the basis of the process fluid characteristics, to adopt all the measures (including use of suitable PPE) so that maintenance operators can work in full safety conditions.

Installation, commissioning, operation

ATTENTION

Carefully check that marks stamped on the nameplates of electric motors, of pumps and, if any, of speed reducers or of hydraulic speed variators, correspond with the category and the temperature class required.

ATTENTION

Read carefully the instructions of the operating handbook of the pump, these supplementary instructions and further possible instructions provided by the Manufacturers of the mechanical seal, of the flexible coupling, of the electric motor, of the speed reducer or of the hydraulic speed variator.



Attend to the connection of motors and pumps to the earth circuit. In case, use the arrangements fitted on the motor frame and on the rear cover of the pump (yellow screw).

ATTENTION

Check the right alignment between pump and electric motor, following the instructions of the operating handbook of the pump and the warnings of the Manufacturer of the flexible coupling .

ATTENTION

Be sure that pipes have proper inner diameters (on the suction side, in particular, inner diameter must not be less than the nominal value of the pump connection), there is no syphon in piping at suction side and there are not air admissions.

ATTENTION

Wherever foreseen, check the connection of the thermocouples and of their related accessories with detecting equipment and with alarm signal and stop device of the pump and of the motor.



We remind you that continuous checking of the surface temperature, connected to an alarm system and to a stop device of the motor **with a safety margin of at least 20°C** with respect to the relevant temperature class, **is mandatory** in the following cases:

- pumps with magnetic couplings);
- pumps with packing rings;
- pumps with internal by-pass valve (if it is not excluded that the full flow by-pass can last more than 60 s.);
- fluids with higher temperature than the one shown in table at page 54.



Check that there are not solid particles in suspension in the fluid or welding wastes inside pipes (they must be flushed). In fact, if they enter the pump, they could seriously damage both bushings and gears; so it is mandatory to provide suction piping with a filter properly dimensioned, taking into account both the capacity of the pump and the head losses of the filter. Choosing the filter, evaluate also the risk due to the generation of electrostatic charges inside (see rule IEC CLC/TR 50404).



If the pump is equipped with a built-in safety valve, check periodically its calibration value. In case safety valve starts working, you must stop the pump as soon as possible (60s max.), and eliminate the anomaly which caused the valve operation, before starting the pump again. Continuous operation in such conditions could cause an unacceptable rising up of surface temperatures. An equipment for detecting outlet flow, joined to an alarm signal and a stop device of the pump, is recommended.

We remind you that every protection device, safety component and safety, control and regulating device installed by the Customer, must be in accordance with requirements of the Directive 2014/34/EU

ATTENTION

Always provide pressure piping (upstream of the stopcock) with an external by-pass valve, joined to the upstream tank. If the pump is already provided with internal relief valve, check that it is calibrated at a pressure value at least 2 bar higher than the by-pass valve.

ATTENTION

Before starting the pump, be always sure that there are no gas or air bubble inside. For this purpose, fill in the pump with fluid, and vent the pump body and connected pipes. **Beware of performing this operation only when pump is stopped and depressurized.** It is a Customer's care, as he well knows the process fluid characteristics, to arrange suitable pipes and devices in order to perform the a.m operations in safety conditions.



Never start the pump when dry. Pumped liquid, other than lubricating gears, also acts as lubricating and cooling fluid for bushings and mechanical seal.



Then, it is a good rule to locate pumps with a positive suction head. In case of negative suction head, whenever the pump starts on, check that it self-primers in 10s max., after that it must be stopped to avoid to damage mechanical parts and overheat bushings and mechanical seal.

This advice must be also adopted during the tests for checking the direction of rotation of the pump.

An equipment for detecting outlet flow, joined to an alarm signal and a stop device of the pump, is recommended.



Before starting on, be sure that both upstream and downstream stop cocks are open and filter is not stopped up. We recommend you to witness every start up.



ATTENTION

At every start, check the mechanical seal, that must not have any loss, check the right operation of thermal sensors and of alarm and stop devices. Verify that in no case the rotation speed exceed 1750 rpm (that is the rotation speed of a 4 poles motor at 60 Hz).

ATTENTION

At every start, check the packing ring, if any. We remind you that during normal operation a little leakage must occur (few drops for minute). Tighten the screws of the stuffing box, if necessary, and/or replace the packing rings.



Even when the check of the temperature is not mandatory, every half an hour during the commissioning and, then, every hour during normal operation, record both the surface temperatures near the bushings and the mechanical seal and the electric absorption of the motor. Shut off the pump as soon as a sudden change happens on the outline of the curve of the recorded values. On the pump body there is an arrangement to install a thermal probe for checking the surface temperature near the mechanical seal (or the packing rings) chamber (white screw). Check also that the ambient temperature and the fluid temperature remain in the range indicated at pag. 54.

Maintenance

A correct and frequent maintenance is the basis for a right operation of the pump.

Maintenance must be done, whenever possible, in unclassified zones, or with no-sparking equipments and tools (see UNI EN 11271 – Annex 2).

Apart from carefully following the instructions supplied by the Manufacturers of the electric motor, of the speed reducer or hydraulic speed variator, the following operations of routine maintenance must be carried out:

- daily (or at every start up) check there are not losses of liquid from the static seals of the pump and of the valve;
- daily (or at every start up) check the tightness of the mechanical seal or of the stuffing box;
- monthly check the wear rate of the radial ball bearing;
- every 2 months check the wear rate on the packing rings;
- every 3 months check the wear rate of the supporting bushes and the gap between the gears and the body;
- every 4 months replace the packing rings;
- every 6 months check the wear rate of the flexible joint;
- every 6 months check the wear rate of the gears;
- every 24 months change the radial ball bearing;
- every 24 months change the supporting bushes;
- every 24 months change all the gaskets.

ATTENTION

Routine maintenance must be supported by extra maintenance to be done every time one detects there is something wrong with the pump (e.g. vibrations, overheating, too large clearances, loss of efficiency,...).



EC - Declaration of Conformity

Manufacturer Details

Tradename

Bedu Pompen BV

Address

Poort van Midden Gelderland Rood 10, 6666 LT, Heteren, Netherlands

Product Details

Product Name

Gear pumps

Model (+series) Name

F-FM-FT series

Applicable Standards Details

Directives

2006/42/EC (Machinery Directive)
2014/35/EU (Low Voltage Directive)
2014/30/EU (Electromagnetic compatibility)

Standards

EN-ISO 12100:2010
EN-IEC 60204-1:2006
EN 809+A1/C1

Additional information

No further details.

Declaration

We hereby declare under our sole responsibility that the product(s) mentioned above to which this declaration relates complies with the above mentioned standards and Directives.

Business Unit Manager: Issued Date:

01/10 2014

BEDU Pompen BV

Poort van Midden Gelderland Rood 10
6666 LT Heteren

Tel : +31 (0)88 - 4802 900

Fax : +31 (0)88 - 4802 901

E-mail : info@bedu.nl

Website : www.bedu.eu

Marco Breunissen

Signature of representative(s)

The logo for BEDU POMPEN is centered in a white square. It features the word "BEDU" in a large, bold, white sans-serif font, with "POMPEN" in a smaller, white sans-serif font below it, separated by three horizontal white lines.

BEDU
≡ POMPEN ≡

made for your process

- Expert advice
- A customer-oriented organization that adapts to the requirements and wishes of your organization
- Innovative and customized solutions
- Breakdownservice, 24 hours a day, 7 days a week
- Technical service with extensive test facilities, working from our own workplace or at your location
- A fast and appropriate solution for all your issues
- Wide range of liquid pumps
- Repair, maintenance and revision

BEDU POMPEN B.V.
Poort van Midden Gelderland Rood 10
6666 LT HETEREN
Nederland
Telefoon +31 (0)88 4802 900
E-mail info@bedu.eu

WWW.BEDU.EU

BEDU BELGIUM B.V.B.A.
Industriepark-West 75
9100 SINT-NIKLAAS
België
Telefoon +32 (0)3 80 87 980
E-mail info@bedu.be

WWW.BEDU.BE

