

BEDU
≡ P O M P E N ≡

*Close-coupled self-priming jet pumps with built-in ejector

NG, NGX, NGL

OPERATING INSTRUCTIONS

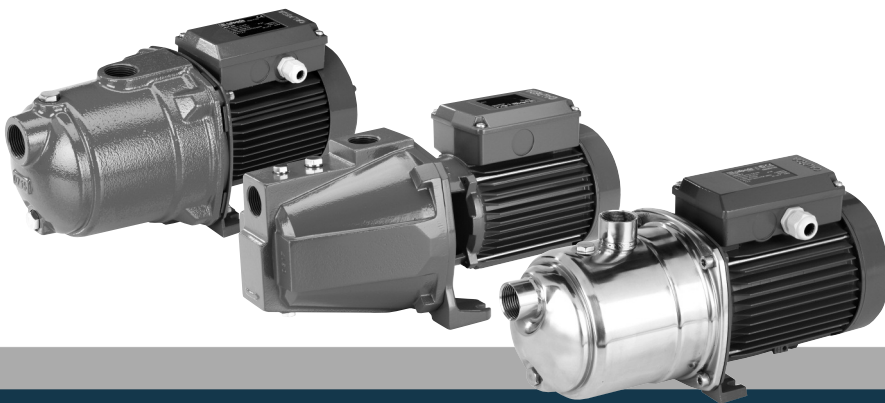

made for your process

SUMMARY

- 1 General information
- 2 TECHNICAL DESCRIPTION
- 3 TECHNICAL FEATURES
- 4 SAFETY
- 5 TRANSPORTATION AND HANDLING
- 6 INSTALLATION
- 7 START-UP AND OPERATION
- 8 MAINTENANCE
- 9 DISPOSAL
- 10 SPARE PARTS
- 11 TROUBLESHOOTING
- 12 ANNEXES
- 12.1 Dimensions and weights
- 12.2 Recommended application limits
- 12.3 Installation examples
- 12.4 Section

Copy of the declaration of conformity

1 GENERAL INFORMATION

Before using the product carefully read the information contained in this instruction manual, the manual should be kept for future reference.

Italian is the original language of this instruction manual, this language is the reference language in case of discrepancies in the translations.

This manual is part of the essential safety requirement and must be retained until the product is finally de-commissioned. The customer, in case of loss, can request a copy of the manual by contacting Bedu Pompen or their agent, specifying the type of product data shown on the label of the machine (see 2.3 Marking)

Any changes, alterations or modifications made to the product or part of it, not authorized by the manufacturer, will revoke the "CE declaration" and warranty.

This appliance should not be operated by children younger than 8 years, people with reduced physical, sensory or mental capacities, or inexperienced people who are not familiar with the product, unless they are given close supervision or instructions on how to use it safely and are made aware by a responsible person of the dangers its use might entail.

Children must not play with the appliance.

It is the user's responsibility to clean and maintain the appliance. Children should never clean or maintain it unless they are given supervision.

Do not use in ponds, tanks or swimming pools or where people may enter or come into contact with the water.

Read carefully the installation section which sets forth:

- The maximum permissible structural working pressure (chapter 3.1).
- The type and section of the power

cable (chapter 6.5).

- The type of electrical protection to be installed (chapter 6.5).

1.1 Symbols

To improve the understanding of the manual, below are indicated the symbols used with the related meaning.



Information and warnings that must be observed, otherwise there is a risk that the machine could damage or compromise personnel safety.



The failure to observe electrical information and warnings, could damage the machine or compromise personnel safety.



Notes and warnings for the correct management of the machine and its parts.



Operations that could be performed by the final user. After carefully reading of the instructions, is responsible for maintenance under normal conditions. They are authorized to affect standard maintenance operations.



Operations that must be performed by a qualified electrician. Specialized technician authorised to affect all electrical operations including maintenance. They are able to operate with in the presence of high voltages.



Operations that must be done performed by a qualified technician. Specialized technician able to install the device, under normal conditions, working during "maintenance", and allowed to do electrical and mechanical interventions for maintenance. They must be capable of executing simple electrical and mechanical operations related to the maintenance of the device.



Indicates that it is mandatory to use individual protection devices.



Operations that must be done with the device switched off and disconnected from the power supply.



Operations that must be done with the device switched on.

1.2 Manufacturer name and address

Bedu Pompen BV

Poort van Midden Gelderland Road 10

6666 LT HETEREN, The Netherlands

1.3 Authorized operators

The product is intended for use by expert operators divided into end users and specialized technicians. (see the symbols above).



It's forbidden, for the end user, carry out operations which must be done only by specialized technicians. The manufacturer declines any liability for damage related to the non-compliance of this warning.

1.4 Warranty

For the product warranty refer to the general terms and conditions of sale.



The warranty covers only the replacement and the repair of the defective parts of the goods (recognized by the manufacturer).

The Warranty will not be considered in the following cases:

- Whenever the use of the device does not conform to the instructions and information described in this manual.
- In case of changes or variations made without authorization of the manufacturer.
- In case of technical interventions executed by a non-authorized personnel.
- In case of failing to carry out adequate maintenance.

1.5 Technical assistance

Any further information about the documentation, technical assistance and spare parts, shall be requested from: Bedu Pompen BV (paragraph 1.2).

2 TECHNICAL DESCRIPTION

Close-coupled self-priming shallow well jet pumps with built-in ejector.

NG, NGL: version with pump casing in cast iron.
 NGX: version with pump casing in stainless steel (AISI 304).
 B-NG: version with pump casing and lantern bracket in bronze.
 (the pumps are supplied fully painted).

2.1 Intended use

For water and other clean liquids which are non-aggressive for the pump materials; for slightly dirty surface water.
 Liquid temperature: 0 °C to +40 °C (from 0 °C to +35 °C for NGL, NGX).

2.2 Improper use

The device is designed and built only for the purpose described in paragraph 2.1.



Improper use of the device is forbidden, as is use under conditions other than those indicated in these instructions.

Improper use of the product reduces the safety and the efficiency of the device. Bedu shall not be responsible for failure or accident due to improper use.



Do not use in ponds, tanks or swimming pools or where people may enter or come into contact with the water.

2.3 Marking

The following picture is a copy of the name-plate (see Pic.1) that is on the external case of the pump.

1 Pump type

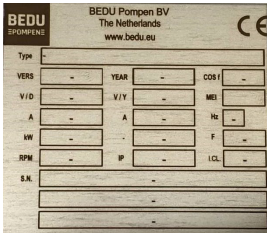

3 TECHNICAL FEATURES

3.1 Technical data

Dimensions and weight (paragraph 12.1).

Nominal speed 2900/3450 rpm

Protection IP54

Supply voltage / Frequency

230V 1~ 50 Hz 230Δ/400Y V3~50 Hz

220V 1~ 60 Hz 220Δ/380Y V3~60 Hz

Sound pressure at minimum immersion depth: < 70 dB(A)

Max. steps per hour: 40 at regular intervals.

Maximum permissible working pressure up to 100 m (10 bar), 80 m (8 bar) for NGL, NGX.

The max. inlet water pressure: PN (Pa) - Hmax (Pa).

3.2 Operating conditions

Installation in well ventilated location protected from the weather, with a maximum ambient temperature of 40 °C.

4 SAFETY

4.1 General provisions



Before using the product it is necessary to know all the safety indications.

Carefully read all operating instructions and the indications defined for the different steps: from transportation to disposal.

The specialized technicians must carefully comply with all applicable standards and laws, including local regulations of the country where the pump is sold.

The device has been built in conformity with the current safety laws. The improper use could damage people, animals and objects.

The manufacturer declines any liability in the event of damage due to improper use or use under conditions other than those indicated on the name-plate and in these instructions.



Follow the routine maintenance schedules and the promptly replace damaged parts, this will allow the device to work in the best conditions.

Use only original spare parts provided from Bedu Pompen BV or from an authorized distributor.



Don't remove or change the labels placed on the device.
 Do not start the device in case of defects or damaged parts.



Maintenance operations, requiring full or partial disassembly of the device, must be done only after disconnection from the supply.

4.2 Safety devices

The device has an external case that prevents any contact with internal parts.

4.3 Residual risks

The appliance, designed for use, when used in-line with the design and safety rules, doesn't have residual risks.

4.4 Information and Safety signals

For this kind of product there will not be any signals on the product.

4.5 Individual protection devices

During installation, starting and maintenance it is suggested to the authorized operators to consider the use of individual protection devices suitable for described activities.

During ordinary and extraordinary maintenance interventions, safety gloves are required.

Signal individual protection device



HAND PROTECTION

(gloves for protection against chemical, thermal and mechanical risks).

5. TRANSPORTATION AND HANDLING

The product is packed to maintain the content intact.

During transportation avoid to stack excessive weights. Ensure that during the transportation the box cannot move.

It is not necessary to use any special vehicle to transport the packaged device.

The transport vehicles must comply, for the weight and dimensions, with the chosen product (see paragraph 12.1 dimensions and weights).

5.1 Handling

Handle with care, the packages must not receive impacts.

Avoid to impact onto the package materials that could damage the pump.

If the weight exceeds 25 Kg the package must be handled by two person at the same time (see paragraph 12.1 dimensions and weights).

6 INSTALLATION

6.1 Dimensions

For the dimensions of the device refer to the annex "Dimensions" (paragraph 12.1 Annexes).

6.2 Ambient requirements and installation site dimensions

The customer has to prepare the installation site in order to guarantee the right installation and in order to fulfill the device requirements (electrical supply, etc...).

The place where the device will be installed must fulfill the requirements in the paragraph 3.2.

It's Absolutely forbidden to install the machine in an environment with potentially explosive atmosphere.

6.3 Unpacking



Inspect the device in order to check any damages which may have occurred during transportation.

Package material, once removed, must be discarded/recycled according to local laws of the destination country.

6.4. Installation

The pumps must be installed with the rotor axis in the horizontal position and with the feet under the pump.

Provide enough clearance around the unit for **motor ventilation** and for filling and draining the pump.

6.4.1. Pipes

Ensure the insides of pipes are clean and unobstructed before connection.

ATTENTION: The pipes connected to the pump should be secured to rest clamps so that they do not transmit stress, strain or vibrations to the pump (par. 12.3 fig. 4).

Tighten the pipes or union coupling to the extent sufficient to ensure a tight seal.

Excessive torque may cause damage to the pump.

When the pipe or union coupling is mounted, keep the pump casing connection blocked with a second wrench, making sure the connection is not deformed by excessive tightening. The pipe diameters must not be smaller than the pump connections.

6.4.2. Suction pipe

For capacities over 4 m³/h use a suction pipe G 1 1/4 (DN 32).

The suction pipe must be perfectly airtight.

With a **pump located above the water level** (suction lift operation, par. 12.3 fig. 1, fig. 3) fit a foot valve with strainer (which must always remain immersed) or a check valve on the suction connection.

If operating with **flexible hoses** use a semi rigid suction hose, in order to avoid the hose narrowing due to suction vacuum.

With the **liquid level on the suction side above the pump** (inflow under positive suction head, par. 12.3 fig. 2) fit an inlet gate valve.

Follow local specifications if increasing network pressure.

Install a strainer on the suction side of the pump to prevent foreign particles from entering the pump.

6.4.3. Delivery pipe

Fit a gate valve in the delivery pipe to adjust delivery and head.

Install a pressure gauge.

6.5 Electrical connection



Electrical connection must be carried out only by a qualified electrician in accordance with local regulations.

Follow all safety standards.

The unit must be properly earthed (grounded).

Connect the earthing (grounding) conductor to the terminal with the ⚡ marking.

Compare the frequency and mains voltage with the name-plate data and connect the supply conductors to the terminals in accordance with the appropriate diagram inside the terminal box cover.



ATTENTION: never allow washers or other metal parts to fall into the internal cable opening between the terminal box and stator. If this occurs, dismantle the motor to recover the object which has fallen inside.

If the terminal box is provided with an inlet gland, use a flexible power supply cord of the H07 RN-F type with section of cable not less than (par. 12.5 TAB 1).

If the terminal box is provided with an inlet bushing, connect the power supply cord through a conduit.

For use in swimming pools (not when persons are in the pool), garden ponds and similar places, a **residual current device** with ΔN not exceeding 30 mA must be installed in the supply circuit.

Install a **device for disconnection from the mains** (switch) with a contact separation of at least 3 mm in all poles.

With a three-phase motor install an overload protection device with curve D appropriate for the rated current of the pump.

Single-phase NGM, NGXM, NGLM, are supplied with a capacitor connected to the terminals and (for 220-240 V - 50 Hz) with an incorporated thermal protector.

7 STARTUP AND OPERATION

7.1 Preliminary checks before start-up of the pump

Do not start-up the device in case of damaged parts.

7.2 First starting



ATTENTION: never run the pump dry. Start the pump after filling it completely with liquid.

When the pump is located above the water level (suction lift operation, par. 12.3 fig. 1, fig. 3) or with a positive suction head which is too low (less than 1 m) to open the non-return valve, fill the pump through the priming hole (par. 12.3 fig. 5).

When the liquid level on the suction side is above the pump (inflow under positive suction head, fig. 2), fill the

pump by opening the suction gate valve slowly and completely, keeping the delivery gate valve open to release the air.

Before starting, check that the shaft turns by hand. For this purpose use the screwdriver notch on the shaft end on the ventilation side.

When starting, with a three-phase motor, check that the direction of rotation is as shown by the arrows on the lantern bracket: clockwise when viewing the motor from the fan end.

Otherwise, disconnect electrical power and reverse the connections of two phases.

7.3. Self-priming

(Capability to clear the air in the suction pipe when starting with the **pump located above the water level**).

Conditions for self-priming:

- suction pipe with connections perfectly airtight and properly immersed in the water to be lifted;
- allow 0,5 m (1 m for NG) minimum of straight vertical pipe above the discharge port (par. 12.2 fig. 1);
- **pump casing completely filled with clean cold water before starting.**

The pump is not self-priming with liquids containing oil, alcohol or foaming substances.

The check valve (par. 12.2 fig. 1) prevents reverse siphoning through the pump when the pump is stopped and retains water in the pump for the next start.

Without a foot valve or a check valve on the suction connection the filling operation must be repeated before each start-up.

ATTENTION: avoid a prolonged operation with unprimed pump, without water delivery from the completely opened outlet (t1, par. 12.2 fig.1, max 22 min).

If necessary, repeat the priming operation after the pump has been first emptied and then completely filled with clean cold water.

7.4. Gate valve regulation

With the gate valve completely open or with an outlet pressure lower than the minimum pressure shown on the name-plate, the pump may be noisy. To reduce noise regulate the delivery gate valve.

7.5. Abnormal operation

Never run the pump for more than five minutes with a closed gate valve.



Prolonged operation without a change of water in the pump causes dangerous increases of temperature and pressure.

Prolonged operation with a closed delivery port causes breakage or damage to parts of the pump (see section 6.2.).

When the water is overheated due to prolonged operation with a closed port, stop the pump before opening the gate valve.

Do not touch the fluid when its temperature is higher than 60 °C.

Do not touch the pump when the surface temperature is higher than 80 °C.

Wait until the water has cooled inside the pump before starting again or opening the draining and filling plugs.

7.6. Automatic regulator IDROMAT

(can be supplied on request)

For automatic control of starting/stopping of the pump when utilization points are opened/closed.

For protection of the pump:

- against dry running;
 - against the risk of operation without water at the inlet (caused by a lack of water inflow in the inlet pipe under positive suction head, by a non-immersed suction pipe, by excessive suction lift or by air entering the suction pipe);
 - against operation with closed connection ports.
- See installation example par. 12.3 fig. 2.

7.7 Switch off of the pump



The appliance must be switch off every time there are faults. (see troubleshooting).

The product is designed for a continuous duty, the switch off is performed by disconnecting the power supply by means the expected disconnecting devices. (see paragraph "6.5 Electrical connection").

8 MAINTENANCE

Before any operations it's necessary to disconnect the power supply.

If required ask to an electrician or to an expert technician.



Every maintenance operations, cleaning or reparation executed with the electrical system under voltage, it could cause serious injuries to people.



If the supply cord is damaged, it must be replaced by the manufacturer, its service agent or similarly qualified persons in order to avoid a hazard.

In case of extraordinary maintenance, or maintenance operations that require part-removing, the operator must be a qualified technician able to read schemes and drawings.

It is suggest to register all maintenance operation executed.



During maintenance keep particular attention in order to avoid the introduction of small external parts, that could compromise the device safety.



It is forbidden to execute any operations with the direct use of hands. Use water-resistant, anti-cut gloves to disassemble and clean.



During maintenance operations external personnel is not allowed.

Maintenance operations that are not described in this manual must be made only by special personnel authorized by Bedu Pompen BV For further technical information regarding the use or the

maintenance of the device, contact Bedu Pompen BV

8.1 Routine maintenance



11. Troubleshooting



WARNING: Turn off the power supply before performing any operations.

Do not allow the pump or motor to run when dry even for a short period.

Strictly follow the user instructions and if necessary contact an authorised service centre.



Before every maintenance operations disconnect the power supply and make sure that the device could not accidentally operate.

When the pump remains inactive it must be emptied completely if there is a risk of freezing (fig. 6).

Before restarting the unit, check that the shaft is not jammed and fill the pump casing completely with liquid.

8.2 Dismantling the system

Close the suction and delivery gate valves and drain the pump casing before dismantling the pump.

9. DISPOSAL



European Directive
2012/19/EU (WEEE)

The final disposal of the device must be done by specialized company.

Make sure the specialized company follows the classification of the material parts for the separation.

Observe the local regulations and dispose the device accordingly with the international rules for environment protection.

10 SPARE PARTS

10.1 Spare-parts request

When ordering spare parts, please quote their designation, position number in the cross section drawing and rated data from the pump name plate (type, date and serial number).

The spare parts request shall be sent to Bedu Pompen by phone, fax, e-mail.

Changes reserved.

PROBLEM	PROBABLE CAUSES	POSSIBLE REMEDIES
1) The motor does not start	1a) Unsuitable power supply 1b) Incorrect electrical connections 1c) Engine overload protective device cuts in. 1d) Blown or defective fuses 1e) Shaft blocked 1f) Motor failed	1a) Check that the mains frequency and voltage are suitable. 1b) Connect the power supply cable correctly. Check the setting of the thermal overload protection. 1c) Check the power supply and make sure that the pump shaft is turning freely. Check the setting of the thermal overload protection. 1d) Replace the fuses, check points a) and c) 1e) See "Blocked pump" instruction booklet 1f) Repair or replace the engine.
2) Pump blocked	2a) Prolonged periods of inactivity 2b) Presence of solid bodies in the impeller 2c) Bearings seized	2a) Unblock the pump by using a screw driver to turn the relevant notch on the back of the shaft. 2b) Remove any solid foreign bodies inside the impeller 2c) Replace the bearings.
3) The pump functions but no water comes out	3a) Presence of air inside the pump or suction pipe 3b) Possible infiltration of air. 3c) Foot valve blocked or suction pipe not fully immersed in liquid 3d) Suction filter blocked	3a) Release the air from the pump using the delivery control valve. 3b) Check which part is not tight and seal the connection. 3c) Clean or replace the bottom valve and use a suitable suction pipe. 3d) Clean the filter, if necessary, replace it. See point 2b) also.
4) Insufficient flow	4a) Pipes and accessories with diameter too small 4b) Presence of deposits or solid bodies in the impeller 4c) Rotor deteriorated 4d) Worn rotor and pump case 4e) Gases dissolved in the water 4f) Excessive viscosity of the liquid pumped 4g) Incorrect direction of rotation	4a) Use pipes and accessories suitable for the specific application 4b) Clean the impeller and install a suction filter 4c) Replace the impeller 4d) Replace the impeller and the pump casing 4e) Perform the opening and closing manoeuvres through the feeder gate 4f) The pump is unsuitable 4g) Invert the electrical connections in the terminal board
5) Noise and vibrations from the pump	5a) Worn bearings 5b) Unbalanced power supply	5a) Replace the bearings 5b) Check that the mains voltage is right
6) Leakage from the mechanical seal	6a) The mechanical seal has functioned when dry or has stuck 6b) Mechanical seal scored by presence of abrasive parts in the liquid pumped 6c) Mechanical seal unsuitable for the type of application 6d) Slight initial drip during filling or on first start-up	In cases 6a), 6b) and 6c), replace the seal 6a) Make sure that the pump casing is full of liquid and that all the air has been expelled. 6b) Install a suction filter and use a seal suited to the characteristics of the liquid being pumped. 6c) Choose a seal with characteristics suitable for the specific application 6d) Wait for the seal to adjust to the rotation of the shaft. If the problem persists, see points 6a), 6b) or 6c).

12. 12.1

Dimensions and weights

NG 3,4,5,6,7

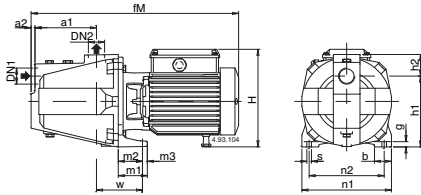

NG 32

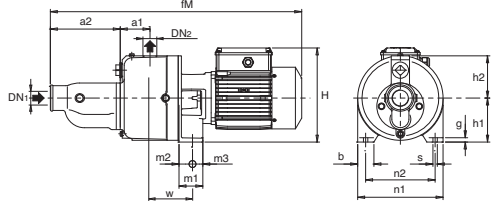

TIPO	DN ₁	DN ₂	mm															kg		
			ISO 228		a1	a2	FM	h1	h2	H	m1	m2	m3	n1	n2	b	s	w	g	NG
NG 3/A NG 4/B	B-NG 3/A B-NG 4/B	G 1 G 1	G 1 G 1	127	8	430	150	43	207	60	52	8	185	155	35	9,5	100	11	18,4 20,0	20,8 22,3
NG 5E NG 6E NG 7/A	B-NG 5E B-NG 6E B-NG 7/A	G 1 1/2 G 1 1/2	G 1 G 1	160	10	560 560 600	165	57	197	60	50	10	215	175	40	11,5	115	11	29,2 30,8 31,3	31,6 32,9 33,4
NG 32E	-	G 1 1/2	G 1	75	175	557	112	108	222	60	34	26	215	175	40	11	106	10	38	-

NGL

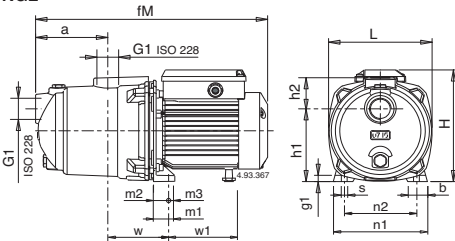

NGX

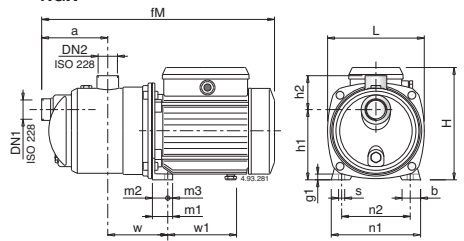

TIPO	DN ₁	DN ₂	mm																	kg	
			ISO 228		FM	a	w	h1	h2	H	L	m1	m2	m3	n1	n2	b	s	g1	w1	3 ~
NGL 2	- NGL 2/80				362					176									102	10,3	10,3
NGL 3/A	- NGL 3/100	G 1	G 1	391	115	95	116	51	192	161	33	25	8	146	112	30	9	10	112	11,4	12,3
NGL 3/13				391					192										112	12,5	13,5
NGL 4/B	- NGL 4/110			391					192										112	13,3	13,5
NGX 2	- NGX 2/80			362					176										102	7,5	7,5
NGX 3/A	- NGX 3/100	G 1	G 1	391	115	95	116	61	192	161	33	25	8	146	112	30	9	10	112	8,7	9,6
NGX 4/B	- NGX 4/110			391					192										112	10,4	10,6
NGX 4/16				462	140	113	152	68	225	213,5	37,5	28	9,5	185	155	33	9,5	11	147	14,5	14,8
NGX 4/18		G 1 1/4	G 1																		
NGX 4/22																					
NGX 5		G 1 1/4	G 1	489	140	113	152	68	240	213,5	37,5	28	9,5	185	155	33	9,5	11	157,5	15,2	16,7
NGX 6																				17,8	18,2

12.2

Recommended application limits, with suction pipe leading constantly upwards to the pump:

50 Hz ($n = 2800$ 1/min), H_2O , $T = 20^\circ C$, $P_a = 1000$ hPa (mbar)

For 60 Hz see the data sheet.

DN 25 (\varnothing_i 28mm)	DN 32 (\varnothing_i 36mm)	NGL 2 NGX 2	NGL 3 NGX 3	NGL 4 NGX 4
Ls 10 m	Ls 10 m	Hs 8 m	Hs 9 m	Hs 9 m
Ls 25 m	Ls 15 m	Hs 6 m	Hs 7 m	Hs 8 m
Ls 50 m	Ls 30 m	-	Hs 6 m	Hs 7 m
Ls 100 m	Ls 60 m	-	Hs 3 m	Hs 4 m

t_1 max 22 min

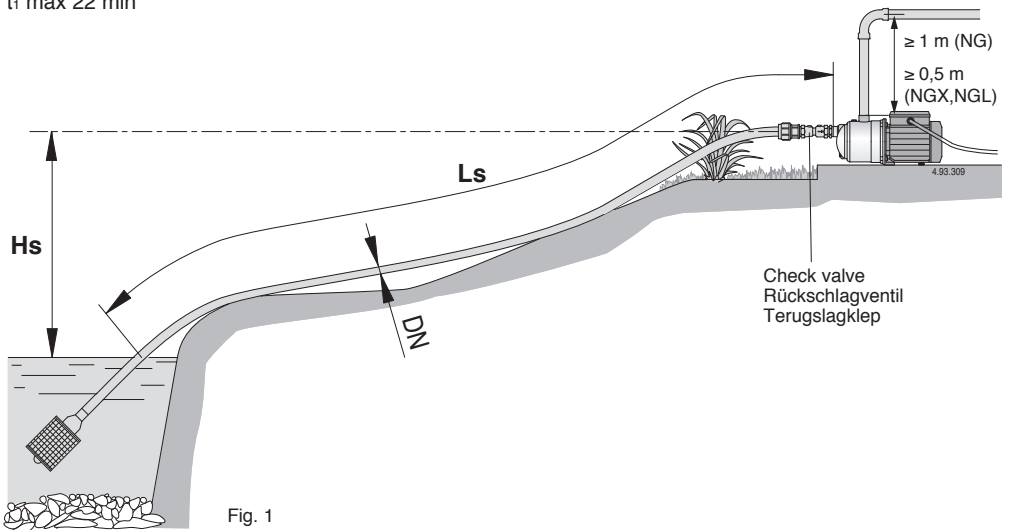

t_1 (min)

Beginning of water delivery

H_s (m)

Suction lift

L_s (m)

Length of suction pipe above the water level

12.3

Installation examples

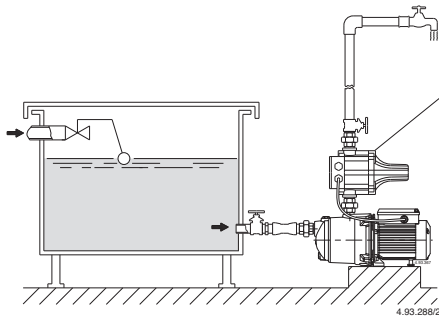

IDROMAT

Fig. 2

Positive suction head operation

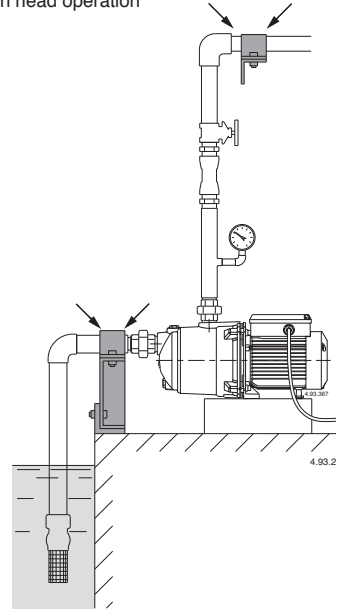

Fig. 3

Suction lift operation

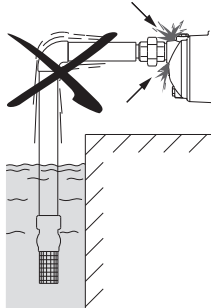
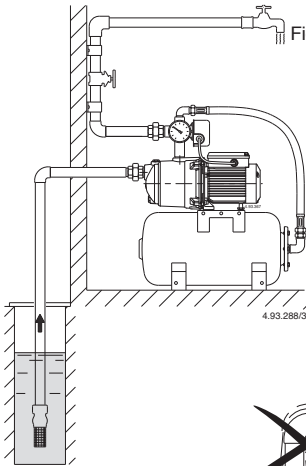

Fig. 4

Supports and clamps for pipelines

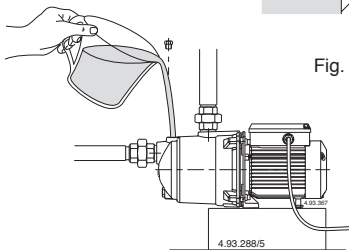

Fig. 5

Filling

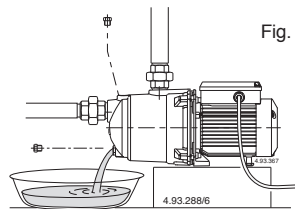

Fig. 6

Draining

12.4.

Drawing for dismantling and assembly

NGX

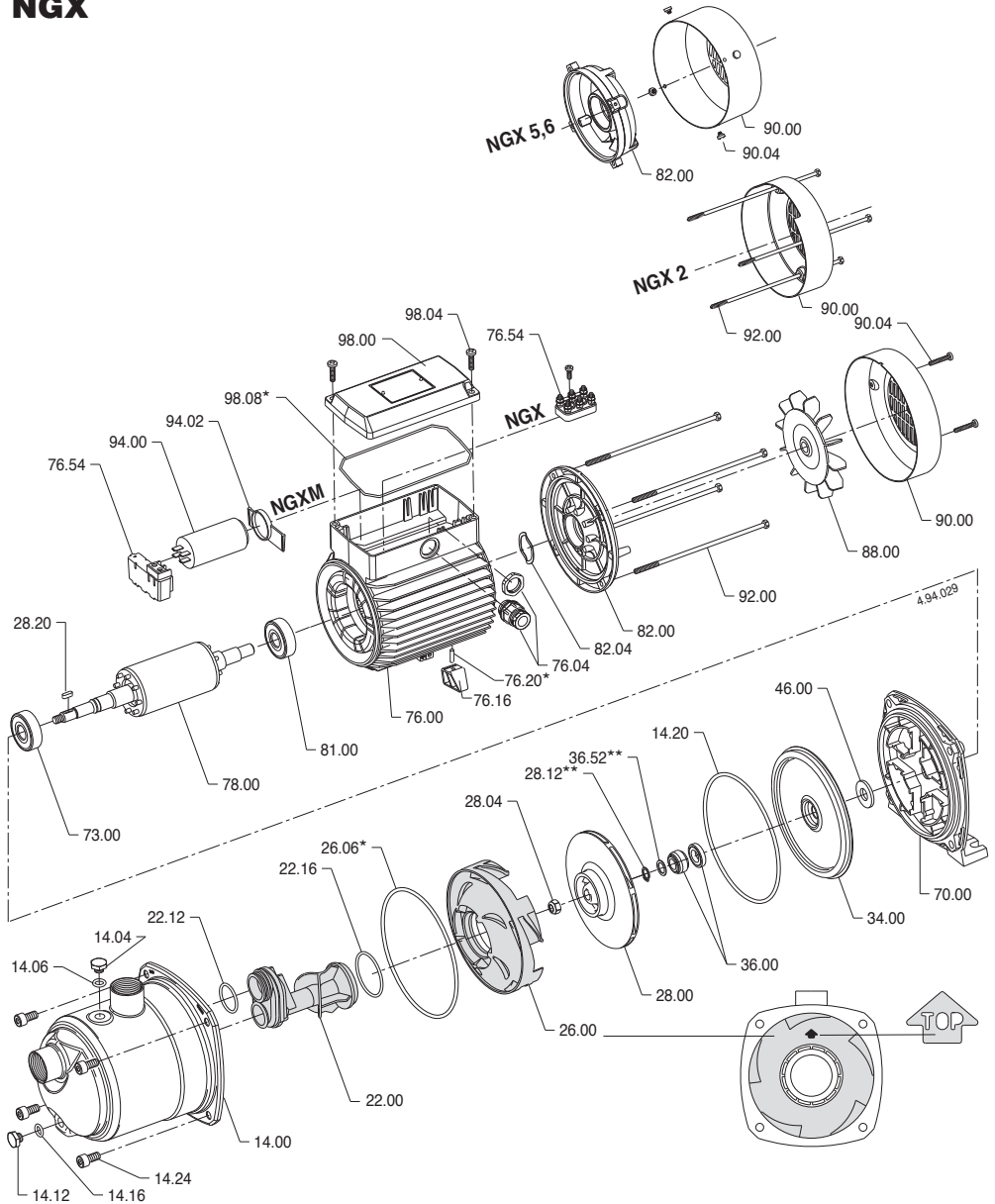

12.4.

Drawing for dismantling and assembly

NGL

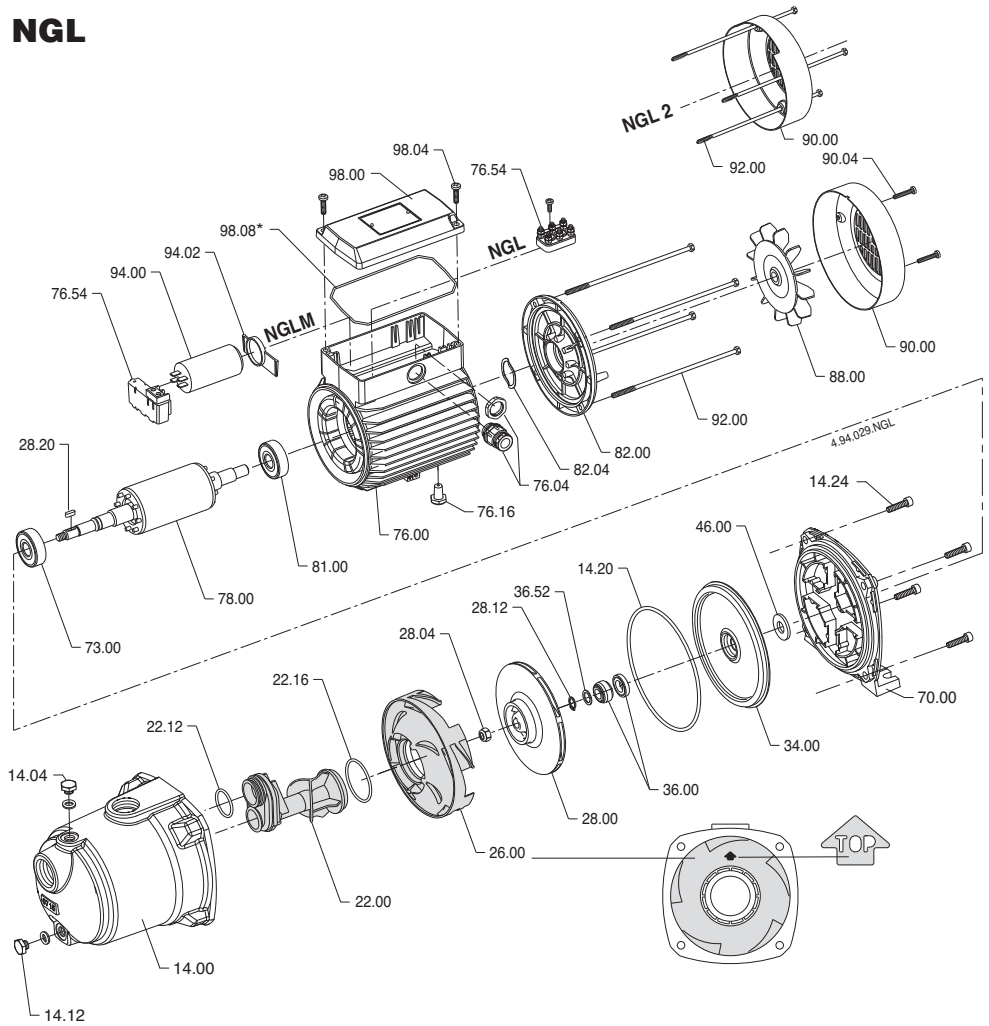

12.4.

Cross section drawings

NG 3,4,5,6,7

NG

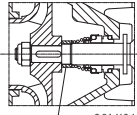
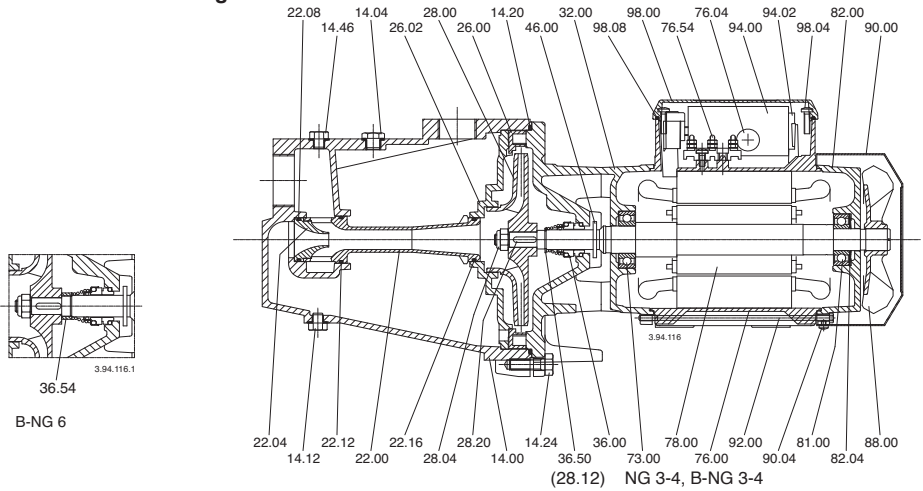

36.54

B-NG 6

NG 32

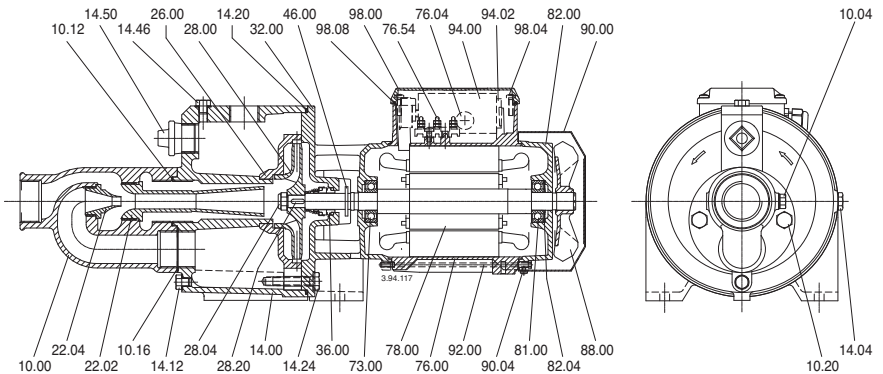

12.5.

Minimum cross-sectional area of conductors

Tab. 1

TAB 1IEC 60335-1

Rated current of appliance A	Nominal cross-sectional area mm ²
>3 + ≤6	0,75
>6 + ≤10	1,0
>10 + ≤16	1,5
>16 + ≤25	2,5
>25 + ≤32	4
>32 + ≤40	6
>40 + ≤63	10



EC - Declaration of Conformity

Manufacturer Details

Tradename

Bedu Pompen BV

Address

Poort van Midden Gelderland Rood 10, 6666 LT, Heteren, Netherlands

Product Details

Product Name

Centrifugal pumps

Model (+series) Name

NG, NGX, NGL series

Applicable Standards Details

Directives

2006/42/EC (Machinery Directive)
2014/35/EU (Low Voltage Directive)
2014/30/EU (Electromagnetic compatibility)

Standards

EN-ISO 12100:2010
EN-IEC 60204-1:2006
EN 809+A1/C1

Additional information

No further details.

Declaration

We hereby declare under our sole responsibility that the product(s) mentioned above to which this declaration relates complies with the above mentioned standards and Directives.

Business Unit Manager: Issued Date:

01/10 2014

BEDU Pompen BV

Poort van Midden Gelderland Rood 10
6666 LT Heteren

Tel : +31 (0)88 - 4802 900

Fax : +31 (0)88 - 4802 901

E-mail : info@bedu.nl

Website : www.bedu.eu

Marco Breunissen

Signature of representative(s)

The logo consists of the word "BEDU" in a large, bold, white sans-serif font, with "POMPEN" in a smaller, white sans-serif font below it. The text is centered within a dark teal square, which is itself centered within a white square border.

BEDU
POMPEN

made for your process

- Expert advice
- A customer-oriented organization that adapts to the requirements and wishes of your organization
- Innovative and customized solutions
- Breakdownservice, 24 hours a day, 7 days a week
- Technical service with extensive test facilities, working from our own workplace or at your location
- A fast and appropriate solution for all your issues
- Wide range of liquid pumps
- Repair, maintenance and revision

BEDU POMPEN B.V.
Poort van Midden Gelderland Rood 10
6666 LT HETEREN
Nederland
Telefoon +31 (0)88 4802 900
E-mail info@bedu.eu

WWW.BEDU.EU

BEDU BELGIUM B.V.B.A.
Industriepark-West 75
9100 SINT-NIKLAAS
België
Telefoon +32 (0)3 80 87 980
E-mail info@bedu.be

WWW.BEDU.BE

