

CENTRIFUGAL SANITARY PUMPS CS - CSX series



HYGIENE



BIOTECHNOLOGY



INDUSTRIAL

Closed coupled hygienic centrifugal pumps with open impellers. CS Series pumps meet the highest requirements of the food, pharmaceutical, chemical and water treatment industries.

The pumps are designed to a modular concept, resulting in a large number of models and a massive performance range.

When combined with the extremely robust construction, these highly efficient pumps become ideal for any hygienic process system.

Wetted parts in CF-3M 1.4404 / AISI 316L stainless steel, investment cast and electro-chemically polished. Special internal finishes to 0,5 micron Ra are available on request (not on sizes 125 to 150). The clamp casing and seal design allows quick disassembly for inspection, cleaning and maintenance. It also enables the delivery port to be rotated to any position for easy installation (not on sizes 125 to 150).

Separate IEC standard motor.

For aggressive products and environments, CS pumps can on special request, be manufactured in the following materials:

- Superduplex
- Nickel steel

Note: upon availability with CSF.

ATEX-compliant versions also available on request.

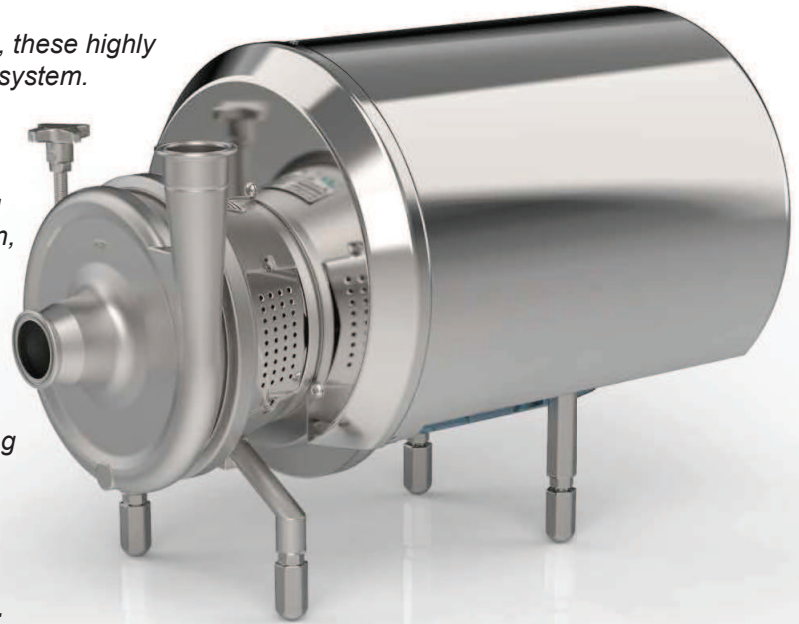

CS pump X execution, close coupled centrifugal pumps with separate support frame and grease lubricated bearings, for extremely arduous applications.

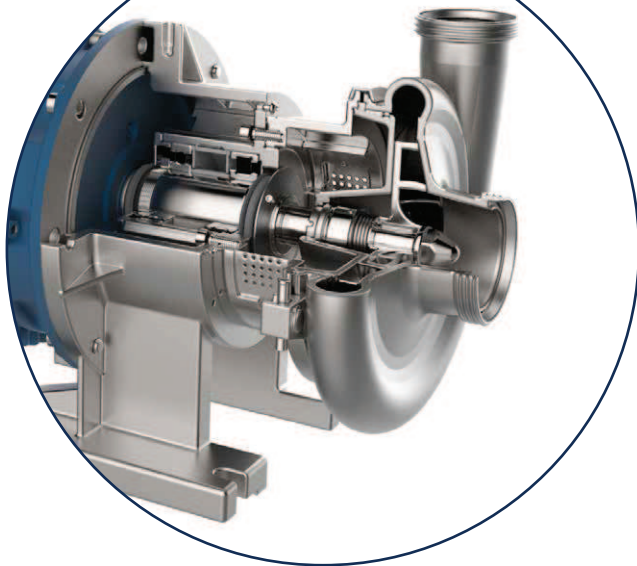

Special version equipped with an inducer in the suction port. This device is fitted immediately upstream of the impeller to reduce the NPSH required by the pump.

GENERAL DIAGRAMS
(Performance applies to H₂O at 20 °C, 1013 mbar, Data not binding)

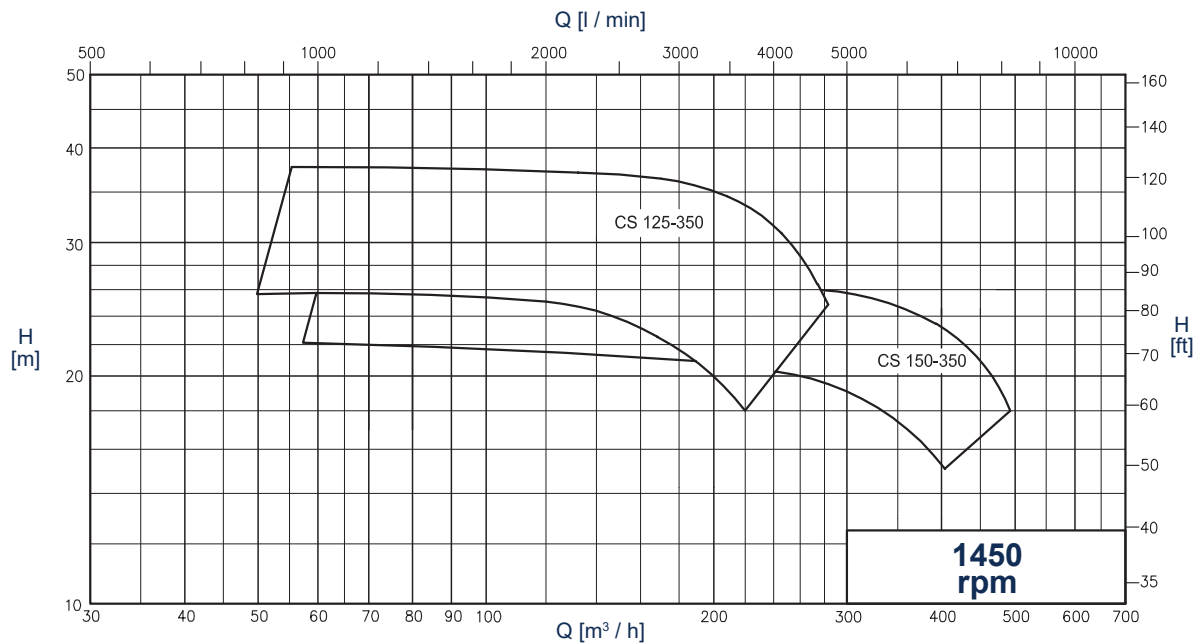
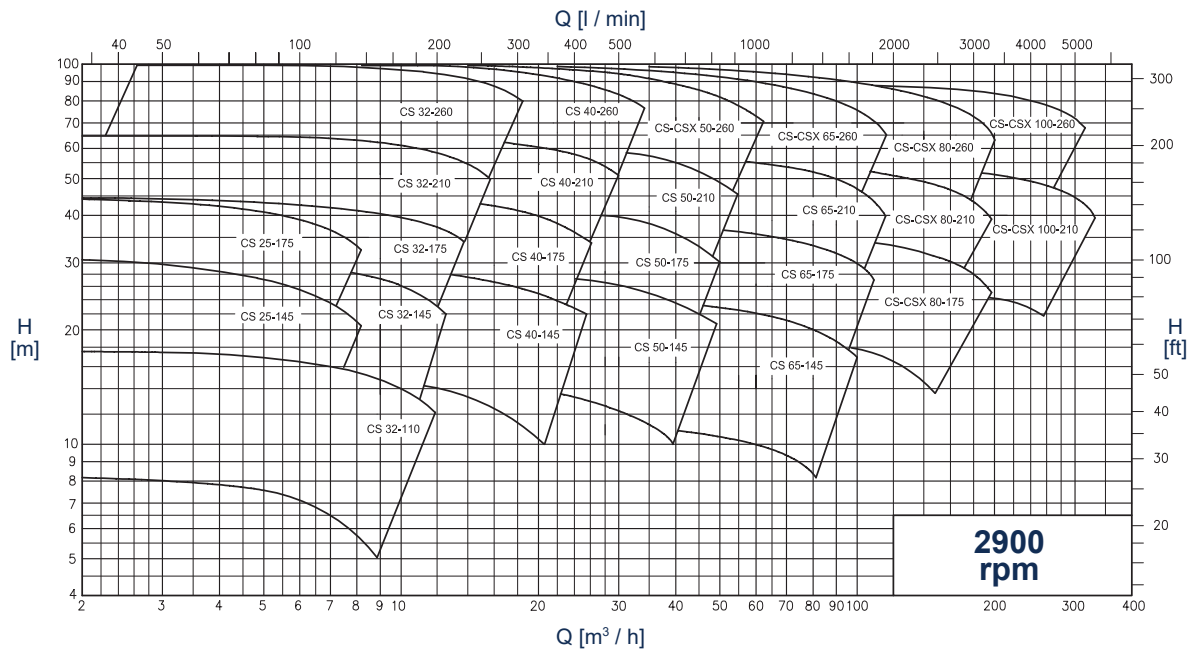
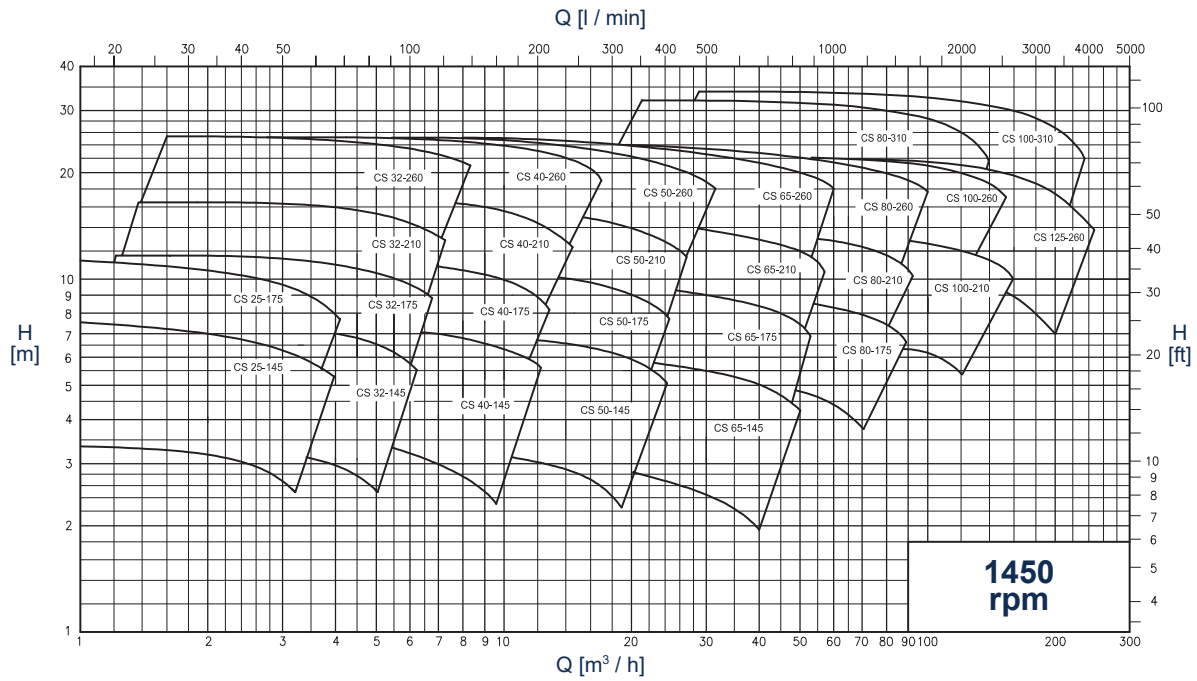

TECHNICAL DATA

Flow rates up to 500 m³/h
 Heads up to 100 mH₂O
 Maximum operating pressure 10 bar up to 100°C
 Temperature range -20°+ +100°
 (on request up to 140 °C for water and up to 190°C for food oil, to be specified on purchase order).
 High performance, with low NPSH values.

Mechanical seals:

With seats to EN 12756, ISO 3069 standards.
 Single internal mechanical seal
 Single external flushed mechanical seal
 Double external flushed mechanical seal

Elastomers (FDA Regulation (EC) No. 1935/2004):

Nitrile (NBR)
 Ethylene propylene (EPDM)
 Special fluorocarbon seal
 Fluorocarbon seal (FPM - FKM)
 FEP
 FFPM - FFKM
 Silicone

Connections:

DIN - SMS - IDF - BS / RJT - DS - CLAMP and
 EN1092-1 PN16 flanges suitable for all international standards.

OVERALL DIMENSIONS

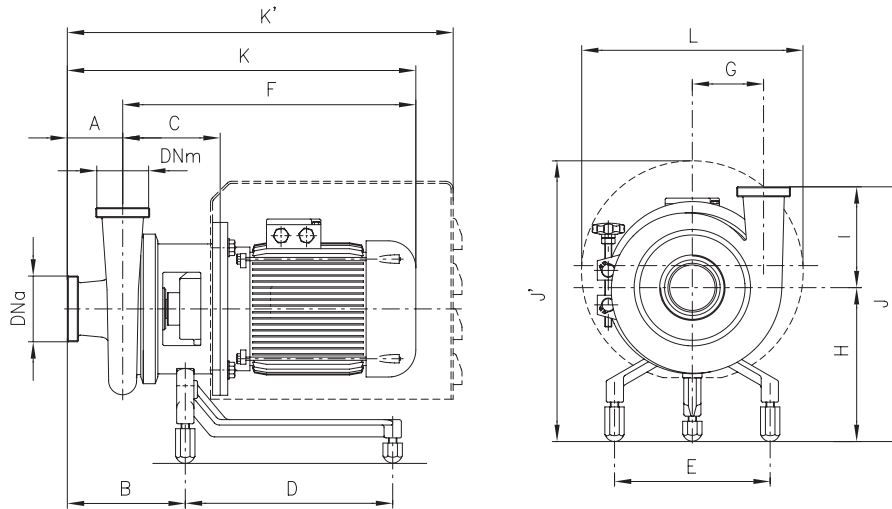

Dimensions not binding - DN = DIN 11851 male threaded connections with standard IEC/EN motors

Pump type	IEC motor dimensions:	DNa	DNm	A	B	C	D	E	F	G	H	K	K'	I	J	J'	L			
CS 25-145	71	32	25	75	144	117	190	178	335	81	158	410	532	145	303	300	239			
	80					359			434			541	340			298				
	90					403			478											
CS 25-175	71	32	25	65	134	117	190	178	335	96	164	400	522	149	313	306	239			
	80					359			424			531	346			298				
	90					403			468											
	100					454			519			619	359			353	330			
CS 32-110	71	40	32	70	137	117	190	178	335	65	149	405	527	110	259	291	239			
	80					359			429			536	331			298				
	90					403			473											
	100					466			531											
CS 32-145	71	40	32	80	167	138	231	225	374	85	208	454	566	145	353	372	298			
	80					418			498											
	90					455			535											
	100					467			547											
CS 32-175	71	40	32	80	167	139	231	225	375	95	213	455	567	150	363	385	298			
	80					419			499											
	90					456			536											
	100					468			548											
CS 32-210	71	40	32	80	158	139	231	225	375	110	221	455	567	165	386	385	298			
	80					419			499											
	90					456			536			636						403	443	330
	100					468			548											
CS 32-260	71	50	32	90	184	163	231	225	443	140	221	533	601	172	393	385	298			
	80					480			570			670						410	443	330
	90					492			582											
	100																			
CS 40-145	71	50	40	80	168	139	231	225	375	90	208	455	567	133	341	372	298			
	80					418			498											
	90					455			535			636						358	430	330
	100					467			547											
CS 40-175	71	50	40	80	169	141	231	225	377	95	213	457	569	150	363	377	298			
	80					421			501			638						380	435	330
	90					458			538											
	100					470			550											
CS 40-210	71	50	40	80	161	141	231	225	377	115	221	457	569	165	386	385	298			
	80					421			501			638						403	443	330
	90					458			538											
	100					470			550											
CS 40-210	112	50	40	80	161	142	301	225	458	115	238	538	638	165	403	443	330			
	112					470			550											

Pump type	IEC motor dimensions:	DNa	DNm	A	B	C	D	E	F	G	H	K	K'	I	J	J'	L
CS 40-260	90	50	40	100	194	163	231	225	443	145	221	543	611	172	393	385	298
	100					164	301		480			580					
	112					164	301		492			592					
CS 50-145	80	65	50	80	170	141	231	225	377	95	208	457	569	145	353	372	298
	90					142	301		421			501					
	100					142	301		458			538					
CS 50-175	112	65	50	80	169	141	231	225	470	100	213	457	569	150	363	377	298
	80					142	301		421			501					
	90					142	301		458			538					
CS 50-210	100	65	50	80	161	141	231	225	421	120	221	501	569	165	386	385	298
	112					142	301		458			538					
	100					142	301		470			550					
CS 50-260	100	65	50	90	185	165	301	225	481	145	238	571	671	175	413	443	330
	112					165	301		493			583					
	100					165	301		481			571					
CS 65-145	80	80	65	79	173	145	231	225	381	112	208	460	572	145	353	372	298
	90					145	231		425			504					
	100					146	301		462			541					
CS 65-175	112	80	65	79	173	146	301	225	474	112	225	553	642	145	370	430	330
	90					144	231		424			504					
	100					145	301		461			541					
CS 65-210	112	80	65	80	172	144	231	225	473	120	230	553	641	150	380	435	330
	90					145	301		461			541					
	100					145	301		473			553					
CS 65-260	112	80	65	90	189	168	231	225	448	135	221	538	605	165	386	385	298
	100					169	301		485			575					
	112					169	301		497			587					
CS 80-175	100	80	65	100	198	168	301	225	484	155	238	584	684	205	443	443	330
	112					168	301		496			596					
	100					168	301		490			590					
CS 80-210	112	100	80	100	204	174	301	225	502	139	230	602	690	164	394	435	330
	100					174	301		487			587					
	112					174	301		499			599					
CS 80-260	100	100	80	100	201	171	301	225	487	165	238	587	687	209	447	443	330
	112					171	301		487			587					
	100					171	301		499			599					

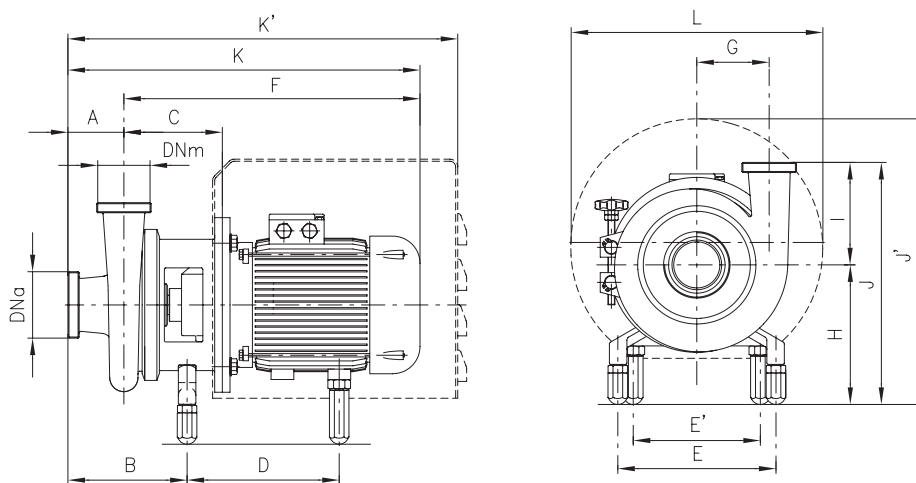

Dimensions not binding - DN = DIN 11851 male threaded connections with standard IEC/EN motors

Pump type	IEC motor dimensions:	DNa	DNm	A	B	C	D	E	F	G	H	K	K'	I	J	J'	L	L					
CS 32-210	132 S	40	32	80	158	161	309	225	198	571	110	238	651	735	165	403	460	370					
	132 M					206	446		254	733			813	907			546	478					
	160					206	446		254	733			813	907			546	478					
CS 32-260	132 S	50	32	90	184	185	318	225	198	595	140	238	685	769	172	410	460	370					
	132 M					225	450		254	752			247	842			940	419	555	478			
	160					225	450		254	752			247	842			940	419	555	478			
CS 40-175	132 S	50	40	80	169	164	301	225	198	574	95	230	654	738	150	380	460	370					
	132 M					161	208		438	254			735	115			238	815	909	165	403	546	478
	160					161	208		438	254			735	115			238	815	909	165	403	546	478
CS 40-210	132 S	50	40	80	161	164	309	225	198	574	115	238	654	738	165	403	460	370					
	132 M					208	446		254	735			815	909			546	478					
	160					208	446		254	735			815	909			546	478					
CS 40-260	132 S	50	40	100	194	185	318	225	198	595	145	238	695	779	172	410	460	370					
	132 M					225	494		254	752			247	852			950	419	555	478			
	160					225	494		254	752			247	852			950	419	555	478			
CS 50-145	132 S	65	50	80	170	164	300	225	198	574	95	225	654	738	145	370	447	370					
	132 M					164	301		198	574			230	654			738	150	380	452	370		
	160					208	438		254	735			100	230			815	909	150	380	538	478	
CS 50-175	132 S	65	50	80	169	164	301	225	198	574	100	230	654	738	150	380	452	370					
	132 M					208	438		254	735			100	230			815	909	150	380	538	478	
	160					208	438		254	735			100	230			815	909	150	380	538	478	
CS 50-210	132 S	65	50	80	161	164	309	225	198	574	120	238	654	738	165	403	460	370					
	132 M					208	446		254	735			120	238			815	909	165	403	546	478	
	160					171	223		494	279			777	248			857	928	165	403	546	478	
CS 50-260	160	65	50	90	186	228	450	225	254	755	145	247	845	943	175	422	555	478					
	180					228	450		254	755			247	845			943	175	422	555	478		
	180					228	450		279	782			247	872			943	175	422	555	478		

Pump type	IEC motor dimensions:	DNa	DNm	A	B	C	D	E	E'	F	G	H	K	K'	I	J	J'	L	
CS 65-145	132 S	80	65	79	173	168	300	225	198	578	112	225	657	741	145	370	447	370	
	132 M					212	437		254	739			818	912			533	478	
	160																		
CS 65-175	132 S	80	65	80	172	167	301	225	198	577	120	230	657	741	150	380	452	370	
	132 M					211	482		254	738			818	912			538	478	
	160				173	224	493		279	778		241	858	929		391	538	478	
	180																		
CS 65-210	160	80	65	90	189	231	450	225	254	758	135	247	848	946	165	412	555	478	
	180					494	279		785	875									
CS 65-260	132 S	80	65	100	198	190	318	225	198	600	155	238	700	784	205	443	460	370	
	132 M					230	450		254	757			247	857			955	205	452
	160				230	494	279		784	230		703	787	394		452	370		
	180																		
CS 80-175	132 S	100	80	100	204	195	316	225	198	603	139	230	703	787	164	394	452	370	
	160				205	236	449		254	763			241	863			961	405	549
	180																		
CS 80-210	132 S	100	80	100	201	193	318	225	198	603	145	238	703	787	165	403	460	370	
	160					233	450		254	760			247	860			958	164	411
	180																		
CS 80-260	132 S	100	80	100	201	193	318	225	198	603	165	238	703	787	209	447	460	370	
	132 M					233	494		254	760			247	860			958	456	555
	160																		
CS 80-310	160	100	80	100	202	235	495	225	254	767	200	250	867	994	250	500	560	480	
	180					533	279		827	927									
CS 100-210	132	125	100	111	219	200	318	225	198	610	161	238	721	805	214	452	460	370	
	180					240	494		279	794			247	905			976	461	555
CS 100-260	132 M	125	100	115	218	195	318	225	198	605	186	238	720	804	216	454	460	370	
	160					235	454		254	762			247	877			975	463	555
	180					235	494		279	789		247	904						
CS 100-310	160	125	100	115	221	239	495	225	254	771	214	250	886	1013	259	509	560	480	
	180					533	279		831	946									
CS 125-260	132 M	150	125	110	223	203	318	225	198	613	206	238	723	621	216	454	460	370	
	160					244	450		254	771			247	881			979	463	555
	180																		

**PUMPS CSX SERIES
FOR POWER OF 30/37 KW
(MOTOR SIZE IEC 200)**

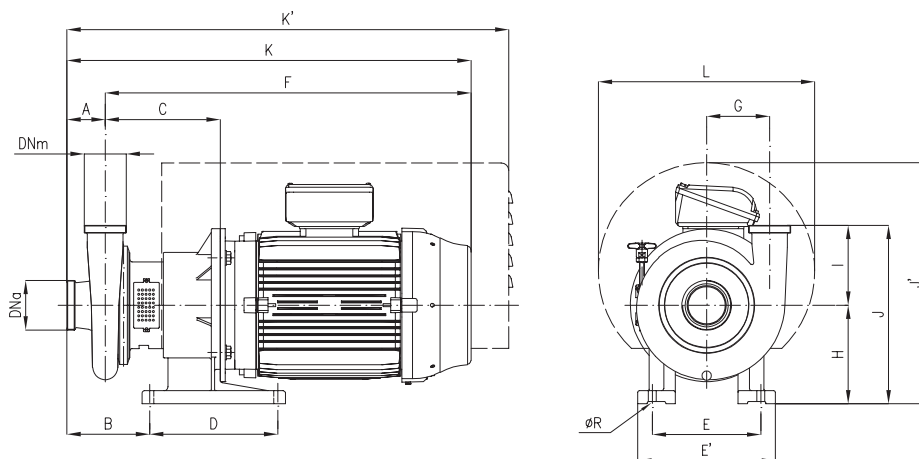

Dimensions not binding - DN = DIN 11851 male threaded connections with standard IEC/EN motors

Pump type	IEC motor dimensions:																	
	DNa	DNm	A	B	C	D	E	E'	F	G	H	K	K'	ØR	I	J	J'	L
CSX 50-260	65	50	90	201	296	335	284	360	915	145	258	1005	1141	21	175	433	613	530
CSX 65-260	80	65	100	213	298				917	155		1017	1153		205	463		
CSX 80-175	100	80	100	219	304				923	139		1023	1159		164	422		
CSX 80-210	100	80	100	216	301				920	145		1020	1156		164	422		
CSX 80-260	100	80	100	216	301				920	165		1020	1156		209	467		
CSX 80-310	100	80	100	218	303				964	200		1064	1154		250	508		
CSX 100-210	125	100	111	234	308				927	161		1038	1174		214	472		
CSX 100-260	125	100	115	233	303				922	186		1037	1173		216	474		
CSX 100-310	125	100	115	237	307				968	215		1083	1172		259	517		
CSX 125-260	150	125	110	237	312				931	206		1041	1177		216	474		