

BEDU
≡ POMPEN ≡

EN 733 NORM PUMPS



SNT



made for your process



SNT NORM PUMPS



Handled Liquids

Clean or slightly contaminated low viscosity liquids without solid & fibrous particles.

Technical Data

Discharge Flange _____ DN 150.....DN 250 mm

Capacity _____ up to 1500 m³/h

Head _____ up to 100 m

Speed _____ up to 1450 rpm

Design Temperature _____ -10 °C' to +140 °C*

Casing Pressure (Pmax) _____ 10 bar (16 bar)*

(Pmax: Suction Pressure + Shut off Head)

(*) The Material of pumps differ according to the type of pumped liquid, operating temperature and pressure. Contact for detailed information.

Design Features

•Horizontal , radially split volute casing type , single stage, end suction centrifugal pump with closed impeller.

•Suction and discharge flanges conform to EN 1092-2 / PN 16. (EN 1092-1 / PN 16 for steel or stainless steel casing)

•Due to the back-pull-out design, the complete bearing assembly including impeller and casing cover can be dismantled without removing the volute casing from the pipe system. (With spacer coupling application, also possible to take out the rotor group without dismantling the electric motor.)

•All impellers are balanced dynamically or statically according to ISO 1940 class 6.3.

•Axial thrust is balanced by impeller balancing holes system.

•Direction of rotation is clockwise viewed from drive end.

•Bearings of SNT type pumps are normally "life time grease lubricated" ball bearings, except the pumps SNT 200-500 and SNT 250-500 which are always oil lubricated.

Shaft Sealing

•In standard production soft packed stuffing boxes are used.

•Depending on customer request, mechanical seals are available. In this case, pump shaft is always stainless steel.

Pump Designation

SNT 150 - 500

Pump Type _____

Discharge Nozzle (DN-mm) _____

Nominal Impeller Diameter (mm) _____

1450 rpm

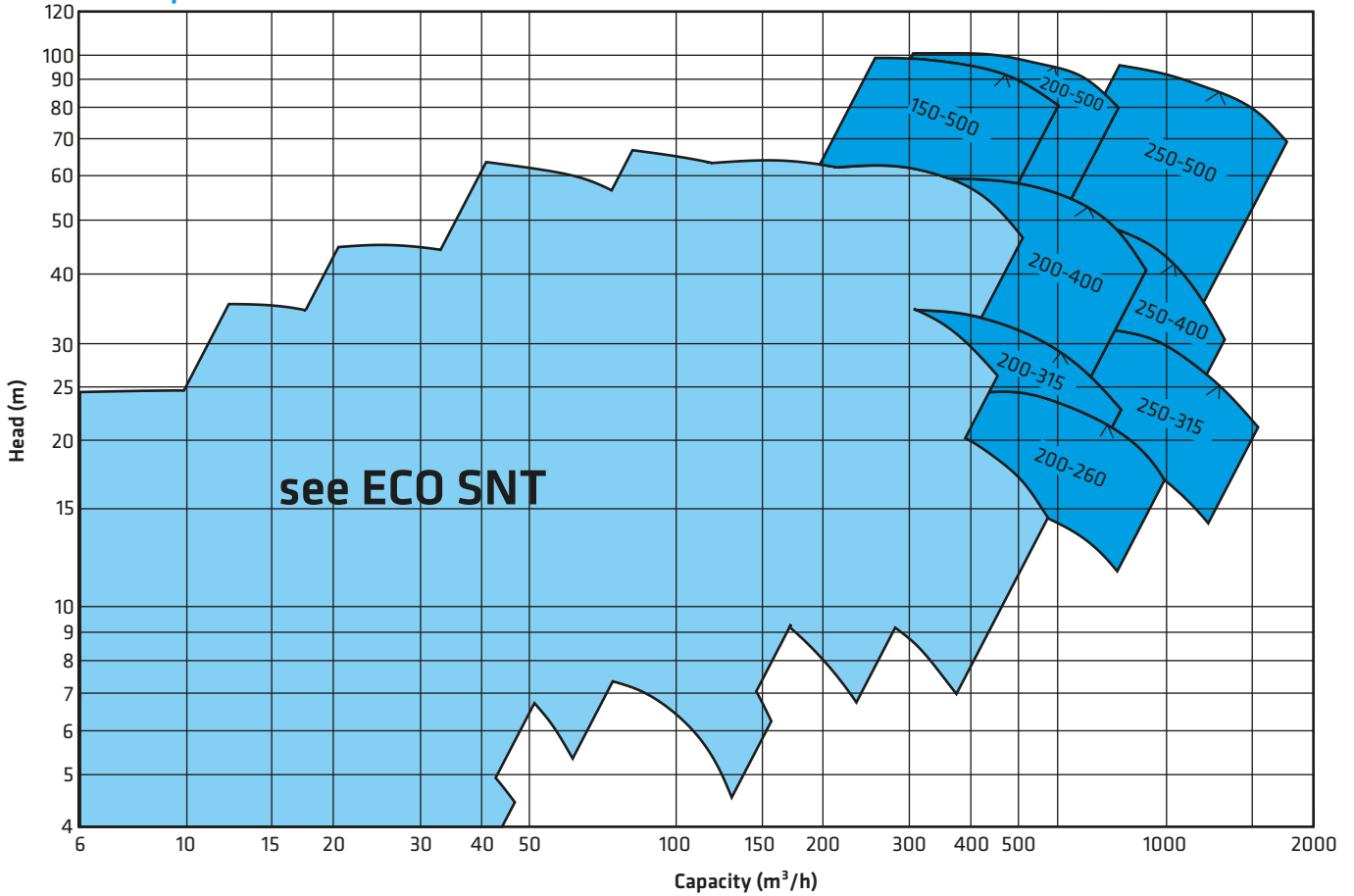

Technical Data

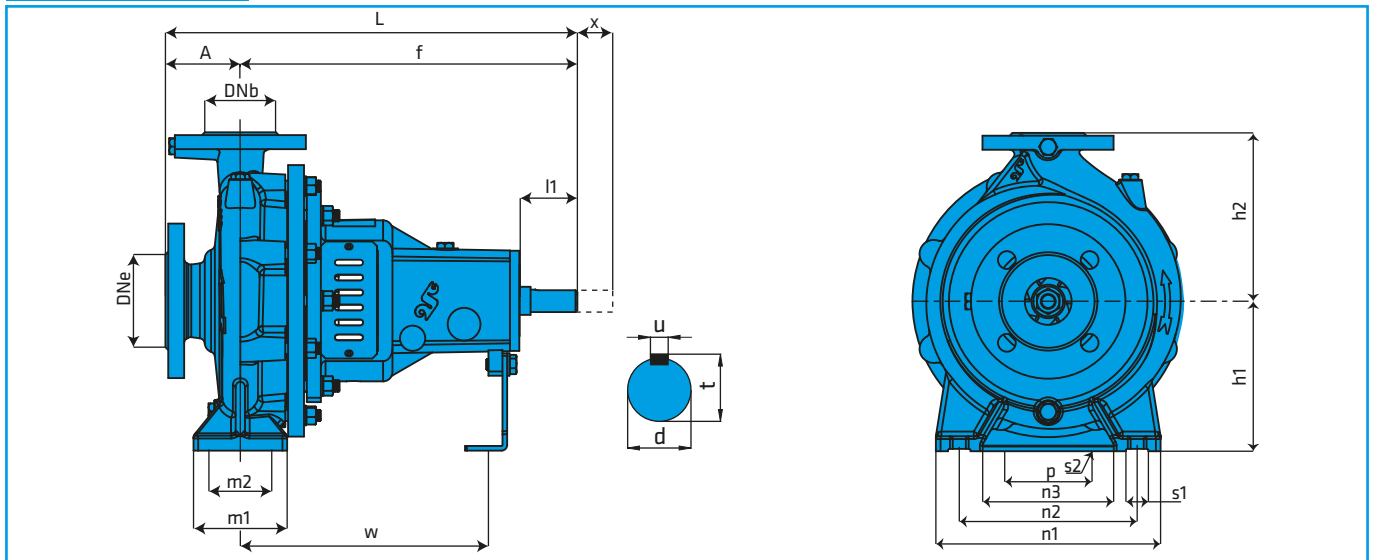

DIMENSIONS

Pump Type	Form	Overall Dimensions						Support & Foot Dimensions										Shaft End		Weight (kg)	Space x**		
		DNe	DNb	A	f	L	h1	h2	m1	m2	n1	n2	n3	s1	p	s2	w	d	l1			t	u
150-500	F2	200	150	200	730	930	400	525	250	200	720	600	435	27	140	20	495	55	110	59	16	480	140
200-260	F1	250	200	200	610	810	355	450	250	200	600	500	360	23	140	20	410	42	110	45	12	280	200
200-315	F1	250	200	200	610	810	355	450	250	200	600	500	360	23	140	20	410	42	110	45	12	300	180
200-400	F2	250	200	180	725	905	400	500	250	200	600	500	360	23	140	20	490	55	110	59	16	360	180
200-500	F3	250	200	210	925	1135	400	525	300	240	720	600	435	27	140	20	640	70	140	74.5	20	640	180
250-315	F1	300	250	230	740	970	400	525	300	240	720	600	435	27	140	20	520	55	110	59	16	390	200
250-400	F2	300	250	230	750	980	400	525	300	240	720	600	435	27	140	20	530	55	110	59	16	460	200
250-500	F3	300	250	225	940	1165	450	630	300	240	720	600	435	27	140	20	670	70	140	74.5	20	660	200

(**) Gap necessary for the withdrawal of the pump rotor from the driven end with out the need for dismantling the motor and pipework (spacer coupling application).

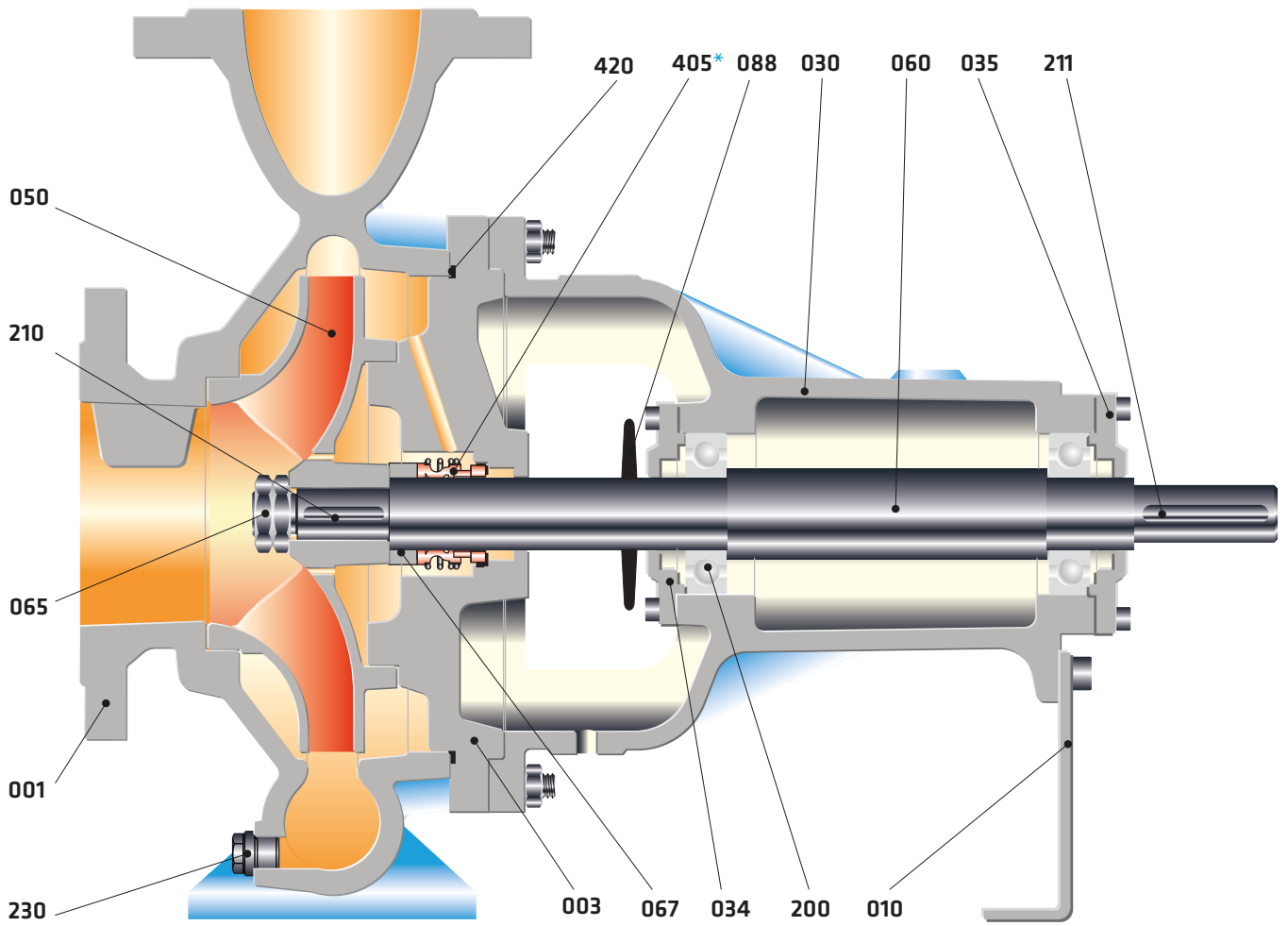

Form F1

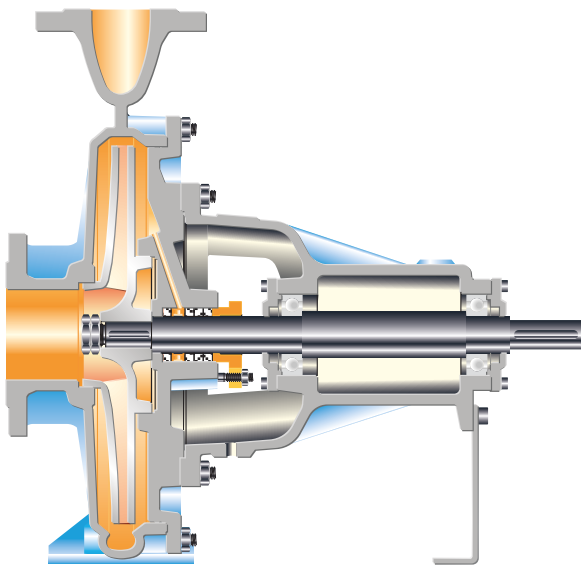

Form F2

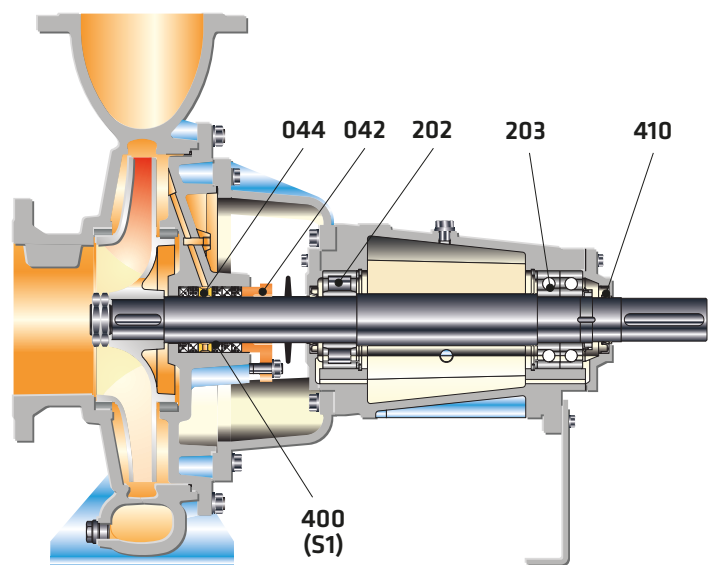

Form F3

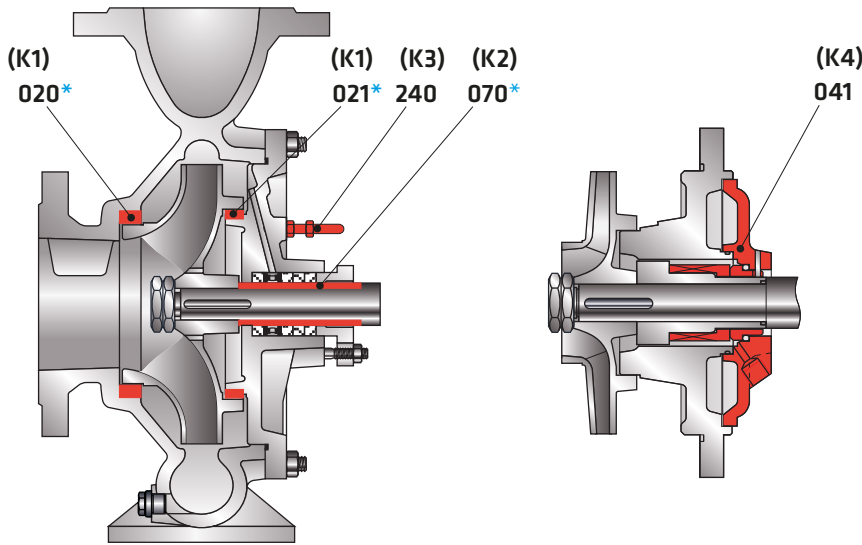

- (K1) Casing wear rings (front - back)
- (K2) Shaft sleeve
- (K3) Sealing fluid from outside source (for pumping contaminated and/or malodorous liquids)
- (K4) Stuffing box cooling (100 °C up to 140 °C)

Part List

001	Volute casing
003	Casing cover
010	Frame foot
020*	Wear ring (casing)
021*	Wear ring (casing cover)
030	Bearing housing
034	Bearing cover
035	Bearing cover
041	Cooling jacket
042	Gland
044	Lantern ring
048	Mechanical seal cover
050	Impeller
060	Pump shaft
065	Impeller nut
067	Spacer sleeve
070*	Shaft sleeve
088	Thrower
200	Ball bearing
202	Cylindrical roller bearing
203	Angular contact ball bearing
210	Impeller key
211	Coupling key
230	Drain plug
240	Seal tubing
400	Stuffing box packing
405*	Mechanical seal
410	Oil seal
420	O-Ring

(*) Optional

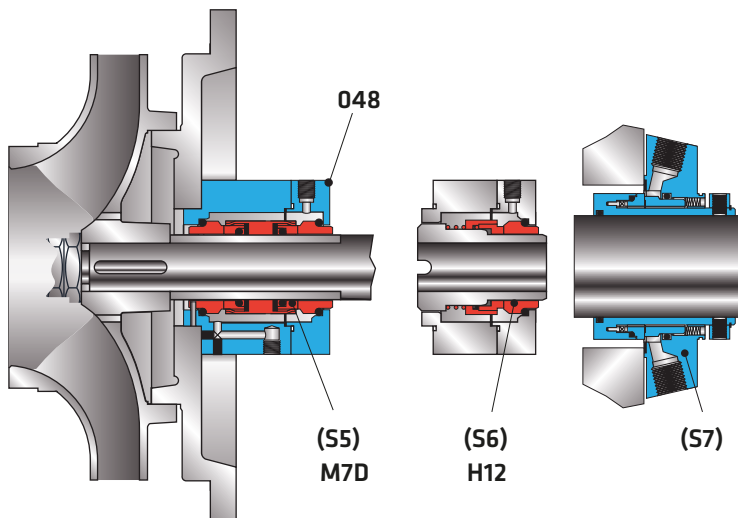
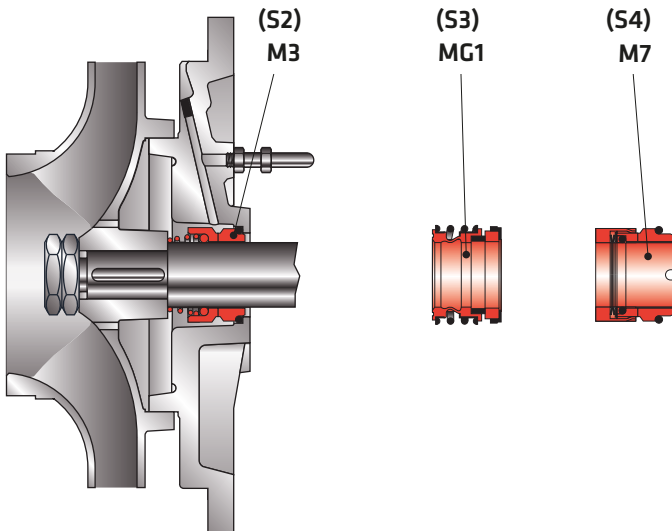

- (S1) Different soft packing types (up to 100 °C)
- (S2) M3 mechanical seal (up to 10 bar - 140 °C)
- (S3) MG1 mechanical seal (up to 12 bar - 140 °C)
- (S4) M7 mechanical seal (up to 16 bar - 140 °C)
- (S5) Double mechanical seal
- (S6) Balanced mechanical seal
- (S7) Cartridge mechanical seal

Part List	10	30	3S	20	60	6L	70	7L	8M	7D	7S	8N	80	4C	4A	40	20	80	8T	60	7L	7E	7D	
	0.6025	0.7040	0.7043	1.0619	1.4308	1.4309	1.4408	1.4409	1.4500	1.4517	1.4469	1.4317	1.4008	2.1050.01	2.0975.01	2.1096.01	1.0503	1.4021	1.4021+QT	1.4301	1.4404	1.4460	1.4462	
Volute Casing	●	○	○	○	○	○	○	○	○	○	○	○	○	○										
Casing Cover	●	○	○	○	○	○	○	○	○	○	○	○	○	○										
Impeller	●	○	○	○	○	○	○	○	○	○	○	○	○	○	○	○							○	
Shaft																	●	○	○	○	○			○
Bearing Housing	●	○	○	○	○	○	○	○																
Wear Ring	○	○	○	○	○	○	○	○	○	○	○	○	○	○	○	○								
Shaft Sleeve																	○	○	○	○	○			○
Mechanical Seal (*)	EN 12756																							

(*) Optional :Depending on customer requirement or request different types and brands of mechanical seals are applicable.

● Standard manufacturing
○ Optional

Material Equivalents

Description	DIN / EN	AISI / SAE / ASTM	
Cast Iron	0.6025	EN-GJL-250 (GG25)	A48 Class 40B
Nodular Cast Iron	0.7040	EN-GJS-400-15 (GGG40)	A536 60-40-18
Nodular Cast Iron	0.7043	EN-GJS-400-18-LT (GGG40.3)	A536 60-40-18
Cast Steel	1.0619	GP240GHGS-C25	A216 WCB
Chrome Nickel Cast Steel	1.4308	GX5CrNi19-10	A351 CF8
Chrome Nickel Cast Steel (low carbon)	1.4309	GX2CrNi19-11	A351 CF3
Chrome Nickel Molybdenum Cast Steel	1.4408	GX5CrNiMo19-11-2	A351 CF8M
Chrome Nickel Molybdenum Cast Steel (low carbon)	1.4409	GX2CrNiMo19-11-2	A351 CF3M
Austenitic Cast Steel	1.4500	GX7NiCrMoCuNb25-20	A351 CN7M
Austenitic - Ferritic Cast Steel (duplex)	1.4517	GX2CrNiMoCuN25-6-3-3	A890 CD4MCuN
Austenitic - Ferritic Cast Steel (super duplex)	1.4469	GX2CrNiMoN26-7-4	A890 CE3MN
Martenzitic Stainless Cast Steel	1.4317	GX4CrNi13-4	A352 CA6NM
Martenzitic Stainless Cast Steel	1.4008	GX7CrNiMo12-1	A217 CA15
Cast Bronze (tin alloy)	2.1050.01	G-CuSn10	B427 C90700
Cast Bronze (nickel alloy)	2.0975.01	G-CuAl10Ni	B148 C95500
Cast Bronze (Leaded)	2.1096.01	G-CuSn5ZnPb	B584 C83600
Carbon Steel	1.0503	C45	AISI 1045
Chrome Steel	1.4021	X20Cr13	A276 Type 420
Chrome Steel (Heat Treated)	1.4021	X20Cr13	A276 Type 420+QT
Chrome Nickel Steel	1.4301	X5CrNi18-10	A276 Type 304
Chrome Nickel Steel (low carbon)	1.4404	X2CrNiMo17-12-2	A276 Type 316L
Duplex (austenitic-ferritic) Steel	1.4460	X3CrNiMoN27-5-2	AISI 329
Duplex (austenitic-ferritic) Steel	1.4462	X2CrNiMoN22-5-3	UNS S32205

Flange Dimensions

EN 1092 - 2	DNe/DNb	Suction & Discharge (PN 16)			
		Df	k	s	n
	32	140	100	19	4
	40	150	110	19	4
	50	165	125	19	4
	65	185	145	19	4
	80	200	160	19	8
	100	220	180	19	8
	125	250	210	19	8
	150	285	240	23	8
	200	340	295	23	12
	250	405	355	28	12
	300	460	410	28	12

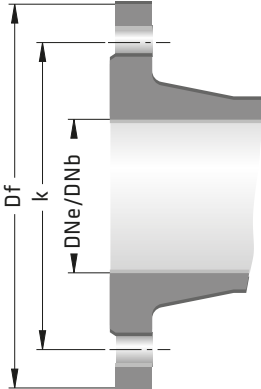
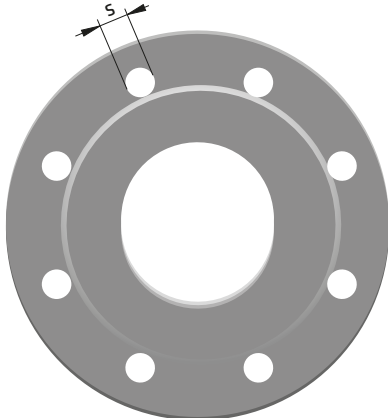
“ n “ number of holes

