

Pump construction

Close-coupled drivers are conventional drivers mounted directly to pumps frame. No base, coupling or guards are required for this mounting style.

Connections:
Flanged DIN PN16 and the ANSI 150#.

Performance curves

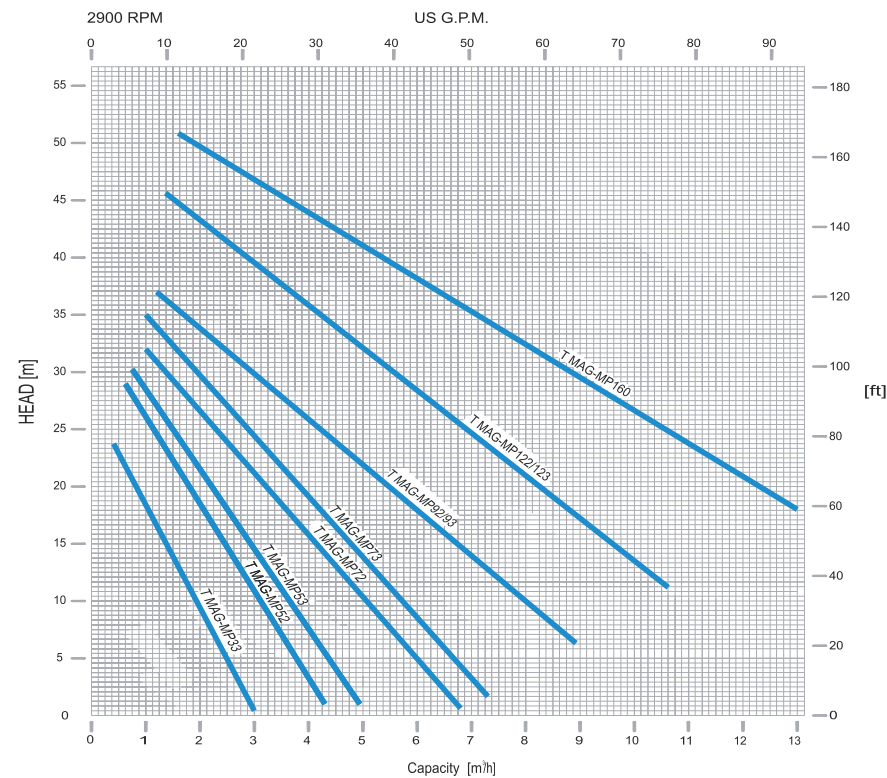

Operating Limits

- Max viscosity: 200 cSt
- Max system pressure: 16 bar
- Flow up: to 13 mc/h
- Head up: to 53 m
- Temperature ratings: from -22 °F (-30 °C) to +194 °F (+90 °C)
- Electric motors: from 0,18 up to 9,2kW
- Available ATEX II - / 3G cbk II C T5

HORIZONTAL, SEALLESS PP AND PVDF ARMORED PERIPHERAL PUMP WITH PERMANENT MAGNET DRIVE SYSTEM, NO MECHANICAL SEAL



T MAG-MP Series

The separation of liquid chamber/atmosphere by means of an isolation shell is the best solution to pump aggressive chemical, high purity liquids and liquids difficult to seal.

The hermetic sealless is the best solution for the chemical and pharmaceutical industry.

A wide range of pumps covers the different performances.

Simple and strong construction combined with high thickness guarantees a long life against the corrosion.

Bedu Pompen B.V.
P v M Gelderland Rood 10
6666 LT HETEREN
Tel: +31 (0)88 4802 900 - Fax: +31 (0)88 4802 901
www.bedu.eu - info@bedu.eu

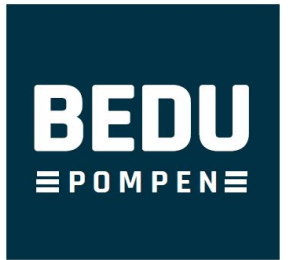

T MAG-MP

PUMP DETAILS

Epoxy primer and polyacrylic enamel water-based painting for the best quality resistance linked to the environmental respect.

The pump casing consist of an external strong carbon steel armour, achieved from precise casting, and an internal casing, achieved from solid bar, that is made of very high tickness PP and PVDF to have a good mechanical resistance and a guaranteed long life against the corrosion.

RWP QUICK CHANGE CARTRIDGE KIT to guarantee an easy and fast maintenance, PP and PVDF materials.

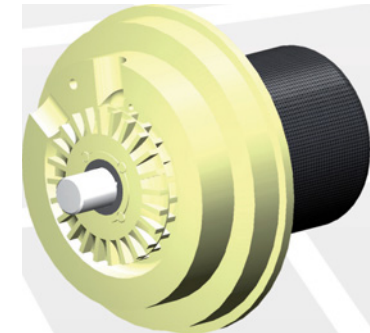

The sealing system with O-Rings prevents from leaking in the atmosphere – different materials available:

- EPDM
- VITON®
- FEP

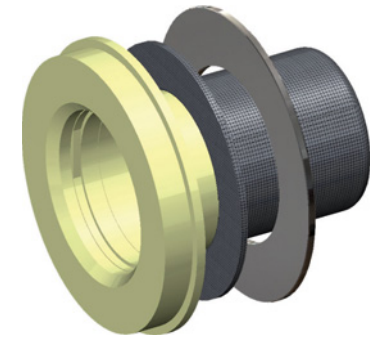
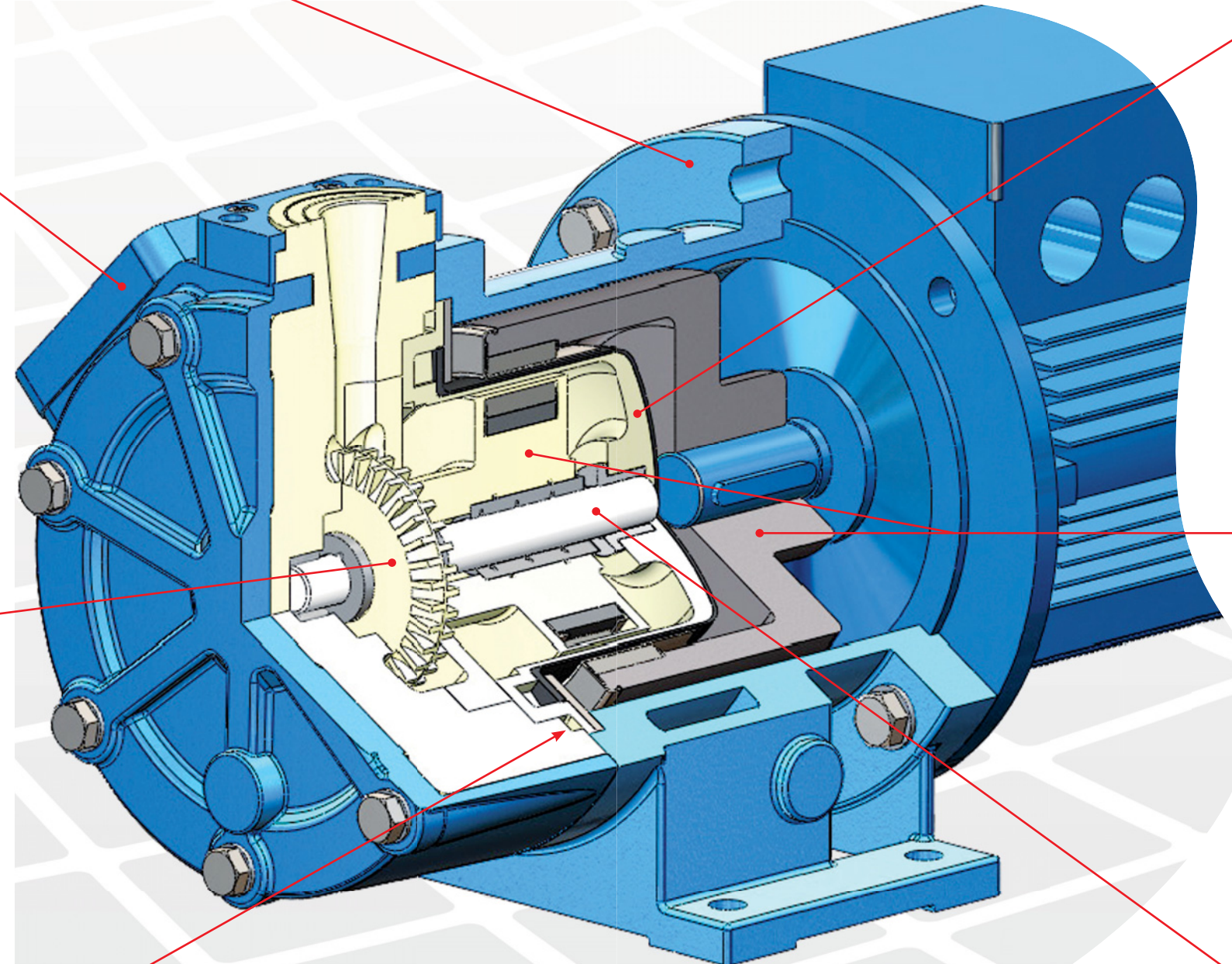

The rear shell is made of thermoplastic materials, as PP GFR or PVDF CFR with zero magnetic losses. Outside rear shell cover ellipsoidal profile made of fiber reinforced composite material.

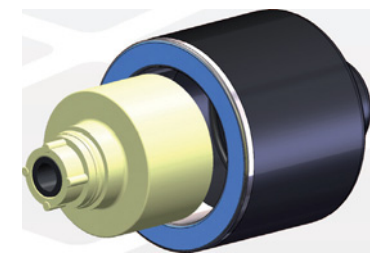

High power synchronous magnetic coupling designed by our Technical Office and with magnetic elements mechanically locked.

Rare earth guarantees the magnetic-balancing to avoid the thrust bearing wear and the heat generation.

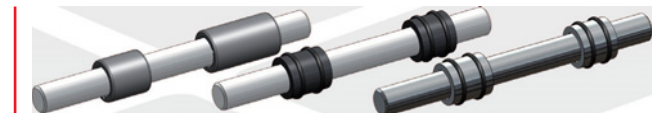

Field assembling of the product lubricated bearing arrangement does not require special tools.

The Shaft / Bearing materials are available in three different configurations to provide the best solution for each application:

- PTFEC – ALLUMINA 99,7% (standard)
- CARBON – ALLUMINA 99,7%
- Silicon Carbide (SSIC) – Silicon Carbide (SSIC)